



Tome 2 - Volume 2
Teil 2 - Tomo 2

CADET

200 Roll Up - 230 Roll Up - 270 Roll Up

200 Aero - 230 Aero - 270 Aero - 310 Aero - 350 Aero

270 ALU - 310 ALU - 350 ALU

édition 00



**LIRE ATTENTIVEMENT CE MANUEL AVANT LA MISE EN SERVICE.
CAREFULLY READ THIS MANUAL BEFORE OPERATING.
LEGGERE ATTENTAMENTE PRIMA DE INIZIARE IL MONTAGGIO .
VOR INBETRIEBNAHME IHRES VORLIEGENDES HANDBUCH AUFMERKSAM LESEN.
LEER CUIDADOSAMENTE ESTE MANUAL ANTES DE PONER EN SERVICIO.**



Tome 2 - Volume 2
Teil 2 - Tomo 2

CADET

200 Roll Up - 230 Roll Up - 270 Roll Up

200 Aero - 230 Aero - 270 Aero - 310 Aero - 350 Aero

270 ALU - 310 ALU - 350 ALU

édition 00



CADET

200 Roll Up - 230 Roll Up - 270 Roll Up

200 Aero - 230 Aero - 270 Aero - 310 Aero - 350 Aero

270 ALU - 310 ALU - 350 ALU

Tome 2

TOME 2

CARACTERISTIQUES TECHNIQUES - PROCEDURE DE MONTAGE



 AVERTISSEMENT	<ul style="list-style-type: none"> ● LISEZ ATTENTIVEMENT CE MANUEL AVANT MISE EN SERVICE DU BATEAU. ● LE MANUEL DU PROPRIETAIRE SE DIVISE EN DEUX TOMES QUI DOIVENT ETRE CONSERVES ENSEMBLE.
---	--

NOTE :	<p>LE MANUEL DU PROPRIETAIRE SE DIVISE EN DEUX TOMES:</p> <p>- LE TOME 1 TRAITÉ D'UNE MANIÈRE GÉNÉRALE DES PRÉCAUTIONS D'USAGE ET DES RECOMMANDATIONS À RESPECTER À BORD DU BATEAU ET SUR L'EAU.</p> <p>- LE TOME 2 TRAITÉ PLUS PARTICULIÈREMENT DES CARACTÉRISTIQUES TECHNIQUES ET DU MONTAGE DU BATEAU ET DE SON ÉQUIPEMENT.</p>
---------------	--

SOMMAIRE

	Page		Page
⇒ Les étapes de la mise en service du bateau	3	⇒ Pression	10
⇒ Inventaire à l'ouverture de l'emballage	3	⇒ Montage de l'équipement	11
⇒ Montage du bateau	4 - 6	⇒ Dégonflage / pliage du bateau	12
⇒ Le système de gonflage	7		
⇒ Gonflage du bateau	8 - 9	⇒ Description générale	I - VI

LES GRANDES ETAPES DE LA MISE EN SERVICE DU BATEAU

La procédure de montage du bateau suit un ordre que nous vous engageons à respecter. Procédez étape par étape en vous reportant à chaque fois aux pages indiquées pour les explications de procédure.

PROCEDURE	PAGE	SECTION
1. faites l'inventaire des éléments qui composent votre bateau, et apprenez à les reconnaître	3	INVENTAIRE A L'OUVERTURE
	I - VI	DESCRIPTION
2. activez les valves en position de gonflage Et gonflez légèrement le flotteur	7	SYSTEME DE GONFLAGE
	8 - 9	GONFLAGE DU BATEAU
3. CADET Solid et Alu : Assemblez le plancher et les longerons CADET Roll Up : Montez les lattes CADET AERO : Gonflez le plancher.	5 - 6	MONTAGE DU BATEAU
	4	
	4	
4. Installez le banc de nage.	11	MONTAGE DE L'EQUIPEMENT
5. terminez le gonflage du bateau aux pressions d'utilisation	8 - 9	GONFLAGE DU BATEAU
	10	PRESSION
6. Mettez en place les avirons	11	MONTAGE DE L'EQUIPEMENT

INVENTAIRE A L'OUVERTURE DE L'EMBALLAGE

 ATTENTION	NE PAS UTILISER D'OUTIL TRANCHANT (CUTTER, COUTEAU, ETC.)
---	--

L'emballage de votre bateau contient 1 flotteur + :

CADET	200-230-270 Roll Up	200-230 Aero	270-310 Aero	270-310-350 Alu
Lattes	X			
Plancher aluminium				X
Plancher gonflable AEROTEC		X	X	
Quille gonflable			X	X
Longerons			X	X
Equipelement standard				
Avirons	2	2	2	2
Gonfleur à pied	1	1	1	1
Banc de nage amovible	1	1	1	1
Sac de transport	1	1	1	1
Mallette de réparation	1	1	1	1
Manuel du propriétaire	2	2	2	2

Vous pouvez équiper votre bateau d'accessoires en option (roues de transport, échelle de bain, anneaux de levage etc ...). Demandez à votre agent de vous conseiller.

NOTE :	SI VOUS SOUHAITEZ AJOUTER DES ANNEAUX DE LEVAGE (POUR LA MISE SOUS BOSSOIRS), VOUS DEVEZ IMPERATIVEMENT LES FIXER SUR LES FLOTTEURS ET NON SUR LE PLANCHER (SAUF 400SR, VOIR « EMBLACEMENT ACCESSOIRES »).
---------------	---

MONTAGE DU BATEAU



PROCEDEZ AU MONTAGE SUR UN SOL PROPRE ET LISSE.
SI LE BATEAU EST STOCKE A UNE TEMPERATURE INFERIEURE A 0°C,
LAISSEZ LE 12 H DANS UN LIEU TEMPERE (20°C) AVANT DE LE DEPLIER .

CADET AVEC PLANCHER À LATTES :

Si les lattes ne sont pas déjà montées, le bateau étant dégonflé, enfitez les lattes dans leurs goussets en commençant par la latte le plus près du tableau arrière. Si l'insertion d'une latte est difficile, lubrifiez celle-ci avec du savon liquide.

CADET AERO: PLANCHER GONFLABLE AERO

plancher Haute Pression DEGONFLE

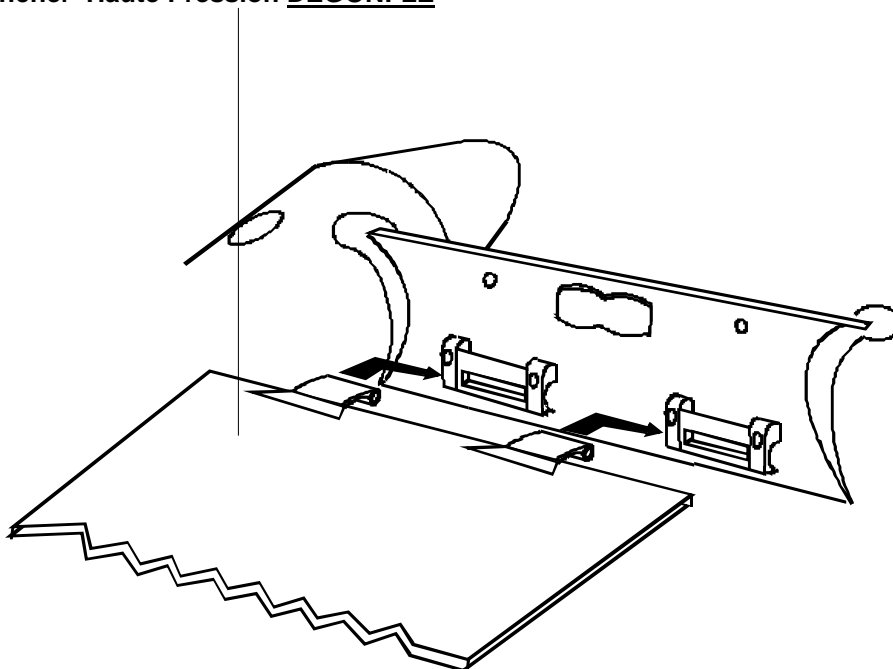

DEMONTAGE/ ENTRETIEN DU PLANCHER GONFLABLE HAUTE PRESSION

Au pliage, nous vous conseillons de laisser le plancher à poste dans le bateau.
Cependant, pour nettoyer le fond du bateau où le sable et autres débris peuvent s'accumuler, il peut être utile de retirer le plancher gonflable. Procédez alors de la manière suivante:

1. **DEMONTAGE:** Dégonflez le flotteur et le plancher.
Faites coulisser la ralingue du plancher hors de ses taquets (procédure inverse de celle du montage).
2. **ENTRETIEN:** Regonflez légèrement le bateau avant de rincer au jet entre le flotteur et le fond, puis levez le nez du bateau pour évacuer l'eau. Répétez l'opération jusqu'à ce que tout le sable ou débris soient évacués.

MONTAGE DU BATEAU

MISE EN PLACE DU PLANCHER CONTREPLAQUE MARINE OU DU PLANCHER ALUMINIUM

- Mettez de la fécule de pomme de terre dans la cornière (bande renforcée située entre le flotteur et le fond, voir figure 1.B) pour faciliter la mise en place des éléments de plancher.

ATTENTION: JAMAIS DE TALC

- **Repérez bien les éléments et leur sens:**
 - Le plancher est composé de trois éléments de plancher et deux volets avant [fg 1].
 - Repérez l'ordre des éléments.
 - Les volets ont un côté endroit et un côté envers. Repérez-vous aux rayures des profilés aluminium de jonction; elles doivent être apparents une fois les éléments montés. Les renforts doivent toujours être sur le dessus.

1. **Gonflez** légèrement le flotteur (cela facilitera la mise en place des éléments de plancher).
2. **Introduisez** le volet avant (1) dans la cornière.
3. **Introduisez** l'élément arrière (5) contre le tableau (6) comme indiqué figure 1.
4. **Emboîtez** les éléments les uns dans les autres [fig.1].
5. **Mettez en "toit"** les éléments de plancher (3) et (4) [fig 1 et 2].
6. **Vérifiez** que l'ensemble est bien aligné [fig 4].
7. **Aplatissez** le toit en montant dans le bateau et en tirant les saisines vers le haut pour éviter de coincer le tissu [fig. 2].
8. **Vérifiez** que le plancher est bien positionné dans la cornière.
9. **Installez** les longerons comme cela est indiqué ci-dessous:

MISE EN PLACE DES LONGERONS :

Les longerons permettent de verrouiller le plancher et d'en rigidifier la structure, élément essentiel pour la bonne navigabilité du bateau.

1. Pour faciliter la mise en place du premier longeron (7), glissez le second longeron sous le fond du bateau à 20 centimètres du bord environ [fig. 3].



NE METTEZ PAS LE LONGERON SOUS LE FOND DU BATEAU AVANT D'AVOIR APLATI LE PLANCHER : LE CHOC POURRAIT LES ENDOMMAGER.

2. **Positionnez** les longerons le long du plancher; le repérage du longeron (8) doit rester sur le dessus [fig. 3].
3. **Assurez-vous** que les longerons sont correctement positionnés entre les butoirs (9) des éléments 3 et 5 [fig. 4].
4. **Faites pivoter** les longerons sur eux-mêmes de façon à ce qu'ils prennent en « sandwich » l'épaisseur du plancher et se positionnent correctement dans le creux de la cornière [fig. 3 et 4].
5. **La structure** auto-serrante du plancher facilitera la mise en place finale des longerons lors du gonflage du flotteur.

MONTAGE DU BATEAU

fig 1-A

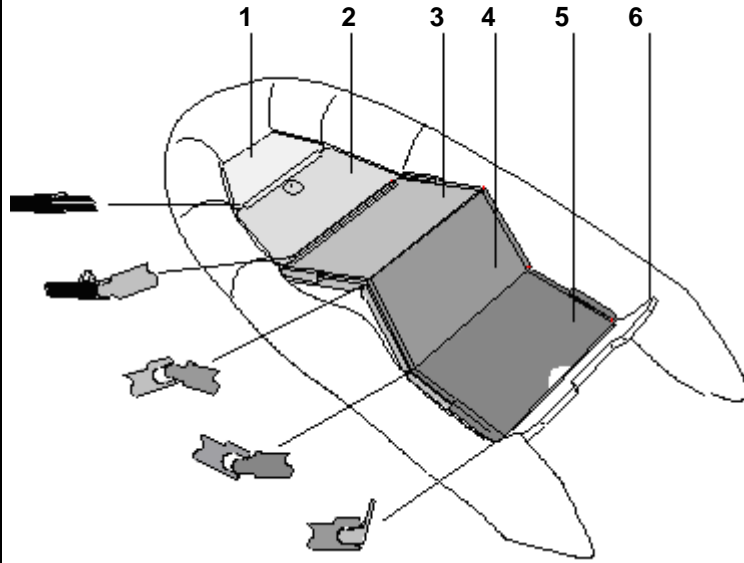

fig 1-B

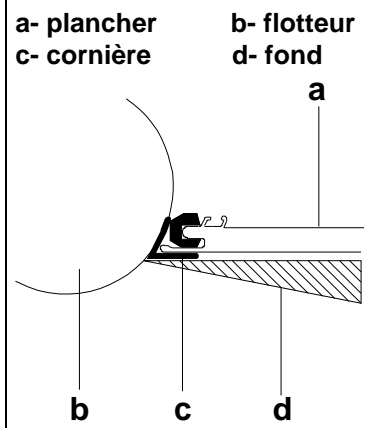

fig 2

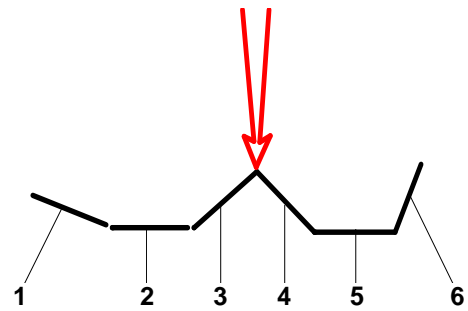
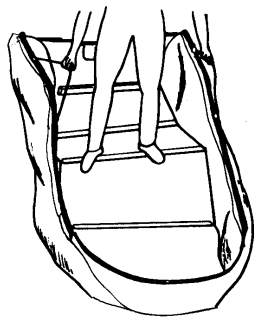

fig 3

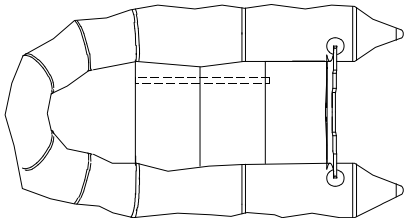
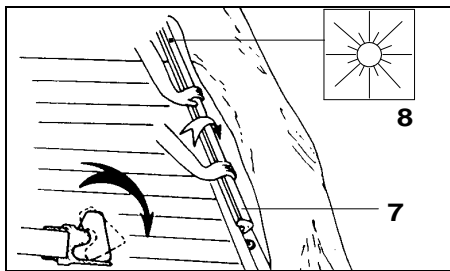
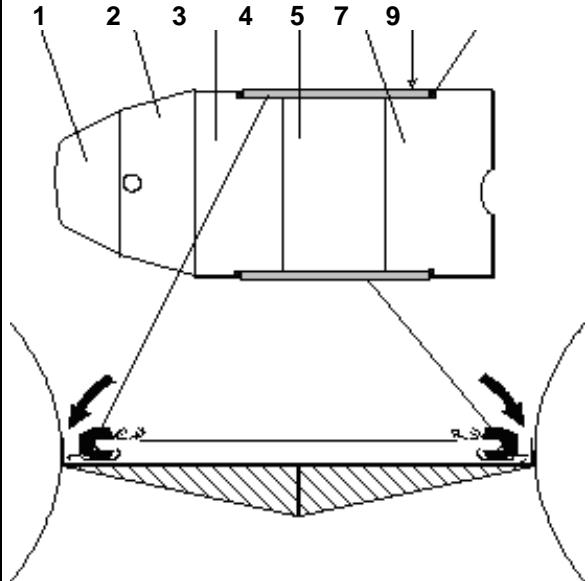





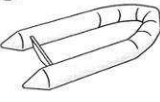
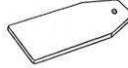

fig 4



LE SYSTEME DE GONFLAGE

Le système de gonflage comprend:

LE GONFLEUR 2 POSITIONS POUR MODELES A PLANCHER GONFLABLE AEROTEC

<p>A</p>  <p>MAX </p> <p>MAX PRESSURE 0,3 bar (4,4 psi)</p> 	<p>B</p>  <p>MAX </p> <p>MAX PRESSURE 1,0 bar (14,7 psi)</p> 	<p>En position A : Bouchon inséré. Le gonfleur développe un débit maximal mais une faible pression: position pour mettre en forme rapidement tous les éléments gonflables.</p> <p>En position B : Bouchon retiré. Le gonfleur développe un débit inférieur à la position A, mais permet d'atteindre avec le même effort une pression supérieure</p> <p>Ne jamais dépasser la pression autorisée.</p> <p>En position C : permet de dégonfler</p>
<p>A</p> 	<p>A + B</p> 	<p>C</p> 

LE GONFLEUR STANDARD (POUR MODELES A LATTES OU A PLANCHER RIGIDE)

- A. embout du tuyau
- B. embase du tuyau
- C. orifice de gonflage

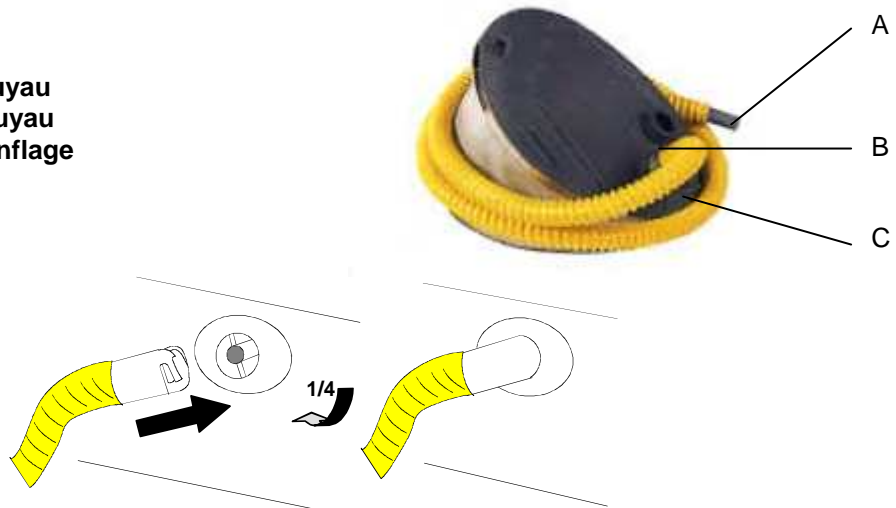

LES VALVES

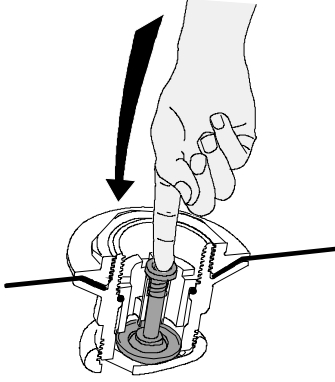
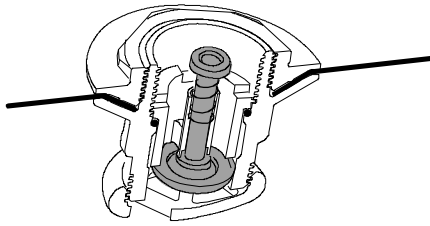
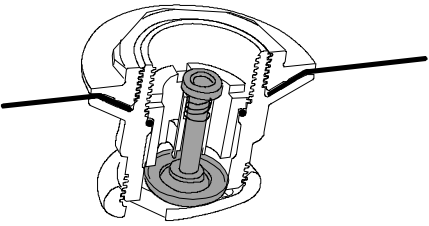
Pour changer de position	en position de gonflage	en position de dégonflage
		
Poussez	La membrane est fermée, le poussoir en position haute	La membrane est ouverte, le poussoir en position basse

GONFLAGE DU BATEAU (MODELES A LATTES ou A PLANCHER RIGIDE)

Activez toutes les valves en position gonflage.

Fixez l'embase du tuyau à l'orifice de gonflage du gonfleur.

Pour bien gonfler votre bateau, il faut que le gonfleur ait une bonne assise sur le sol.

Le bateau se gonfle rapidement si le gonfleur est actionné en souplesse et sans précipitation.

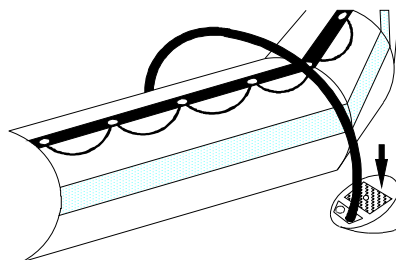



 ATTENTION	NE PAS UTILISER DE COMPRESSEUR OU DE BOUTEILLE A AIR COMPRIME.
---	---

Vous pouvez utiliser le gonfleur électrique ACCESS en vente chez votre agent.

GONFLAGE DU FLOTTEUR

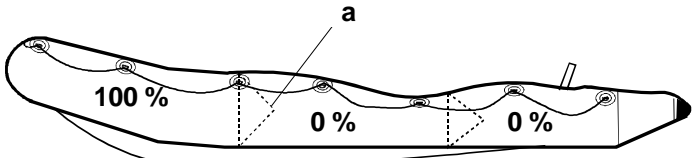
Procédez au gonflage du flotteur en équilibrant les pressions entre les différents compartiments, jusqu'à ce que les cloisons (a) ne soient plus visibles (voir chapitre « Pression »).

	NE JAMAIS METTRE UN COMPARTIMENT SOUS PRESSION LES AUTRES ETANT COMPLETEMENT DEGONFLES	
---	---	--

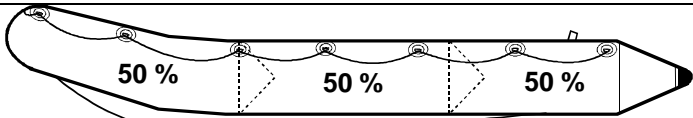
	1	
---	---	--

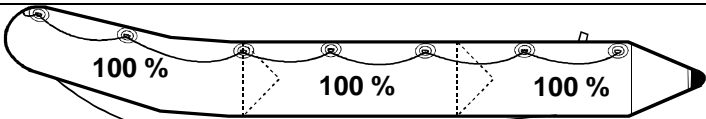
	2	
---	---	--

GONFLAGE DE LA QUILLE

- Une fois le plancher monté, procédez au gonflage de la quille (voir chapitre **PRESSION**).

Le gonflage est terminé: vissez les bouchons des valves de gonflement.

NOTE :	Il est normal de constater une légère fuite d'air avant le vissage du bouchon de valve. SEULS LES BOUCHONS ASSURENT L'ETANCHEITE FINALE.
---------------	--

GONFLAGE DU BATEAU (AVEC PLANCHER GONFLABLE AERO)

Activez toutes les valves en position gonflage.

Fixez l'embase du tuyau à l'orifice de gonflage du gonfleur.

Pour bien gonfler votre bateau, il faut que le gonfleur ait une bonne assise sur le sol.

Le bateau se gonfle rapidement si le gonfleur est actionné en souplesse et sans précipitation.

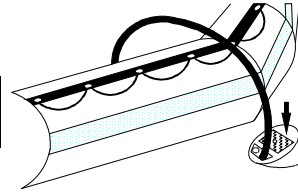

 ATTENTION	NE PAS UTILISER DE COMPRESSEUR OU DE BOUTEILLE À AIR COMPRIME.
----------------------	---

A - GONFLEZ LE PLANCHER AERO (voir chapitre PRESSION).

UTILISEZ LE GONFLEUR 2 POSITIONS

1. Insérez le tuyau comme indiqué dans la figure A et commencez à gonfler **en laissant le bouchon inséré**. Gonflez jusqu'à ce que le maniement devienne dur.
2. **Puis enlevez le bouchon**. Terminez le gonflage en position B jusqu'à atteindre la pression recommandée (voir chapitre PRESSION).
- 3.

B - GONFLEZ LE FLOTTEUR PRINCIPAL ET LA QUILLE (voir chapitre PRESSION).

 ATTENTION	<p>PRESSION MAXIMUM FLOTTEUR ET QUILLE (voir chapitre PRESSION).</p> <p><u>N'UTILISEZ JAMAIS LA POSITION B DU GONFLEUR POUR GONFLER LE FLOTTEUR OU LA QUILLE, VOUS RISQUERIEZ L'ECLATEMENT.</u></p>
----------------------	--

1. **Gonflez** le flotteur avec le soufflet en position A (bouchon inséré), et gonflez jusqu'à atteindre la pression recommandée (240 mb) **en équilibrant les pressions entre les différents compartiments**, jusqu'à ce que les cloisons (a) ne soient plus visibles. (voir chapitre PRESSION).
2. **Gonflez** ensuite la quille selon le même procédé. (voir chapitre PRESSION).

	NE JAMAIS METTRE UN COMPARTIMENT SOUS PRESSION LES AUTRES ETANT COMPLETEMENT DEGONFLES	
--	---	--

	1	
--	---	--

	2	
--	---	--

Le gonflage est terminé: vissez les bouchons des valves de gonflement.

NOTE :	<p>Il est normal de constater une légère fuite d'air avant le vissage du bouchon de valve.</p> <p style="text-align: center;">SEULS LES BOUCHONS ASSURENT L'ETANCHEITE FINALE.</p>
---------------	---

PRESSION

La pression d'utilisation pour le flotteur et la quille est de 240 mb (3,48 PSI); celle du fond gonflable Aerotec est de 600 mb (8.5 PSI).

Si votre bateau n'est pas équipé d'un indicateur de pression **ACCESS**, nous vous recommandons de vous en procurer un chez votre agent. Il vous permettra une lecture rapide et efficace pendant le gonflage. Sans indicateur de pression, arrêtez de gonfler dès que le flotteur est suffisamment ferme pour que l'on ne puisse plus couder à la main les cônes à l'arrière du flotteur.

La température ambiante de l'air ou de l'eau influe proportionnellement sur le niveau de la pression interne du flotteur:

Température ambiante	pression interne du flotteur
+1°C	+4 mb / 0,06 PSI
-1°C	-4 mb / 0,06 PSI

Aussi, est-il important de savoir anticiper :

Vérifiez et ajustez la pression des compartiments gonflables (en regonflant ou en dégonflant selon le cas) en fonction des variations de température (surtout lorsque les écarts de température sont importants entre le matin et le soir dans les zones particulièrement chaudes) et assurez vous que la pression ne s'écarte pas de la zone de pression recommandée (de 220 à 270 mb / zone verte).

RISQUE DE SOUS-PRESSION

EXEMPLE: Votre bateau est exposé sur la plage en plein soleil (température=50°C) à la pression recommandée (240 mb/3,48 PSI). Lorsque vous le mettez à l'eau (température=20°C), la température et la pression interne des compartiments gonflables vont conjointement baisser (jusqu'à 120 mb) et **IL VOUS FAUDRA ALORS REGONFLER** jusqu'à regagner les millibars perdus à cause de l'écart de température entre l'air ambiant et l'eau. Ainsi il est normal de constater une diminution de pression en fin de journée lorsque la température extérieure baisse.

NOTE :

Sous-gonflé, votre bateau manque de rigidité en navigation, offre de mauvaises performances et risque de vieillir prématurément.

RISQUE DE SURPRESSION

EXEMPLE: Votre bateau est gonflé à sa pression recommandée (240 mb/3,48 PSI) en début ou fin de journée (température extérieure basse=10°C). Plus tard dans la journée, votre bateau est exposé en plein soleil sur la plage ou sur le pont d'un yacht (température=50°C). La température intérieure des compartiments gonflables peut alors s'élever et atteindre jusqu'à 70°C (flotteurs de couleur foncée notamment) entraînant un doublement de la pression de départ (480 mb). **IL VOUS FAUDRA ALORS DEGONFLER** afin de revenir à la pression recommandée.



ATTENTION

SI VOTRE BATEAU EST TROP GONFLE, LA PRESSION SOLLICITE DE FAÇON ANORMALE LA STRUCTURE GONFLABLE POUVANT ENTRAÎNER UNE RUPTURE D'ASSEMBLAGE.

EN CAS DE SURPRESSION

Libérez de l'air en appuyant sur le poussoir de la valve

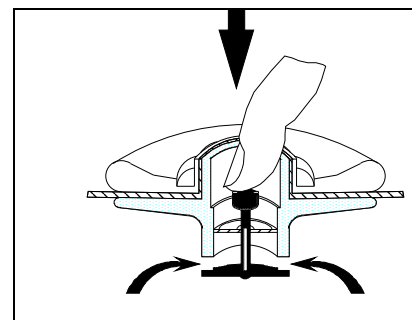

MONTAGE DE L'EQUIPEMENT

LES AVIRONS

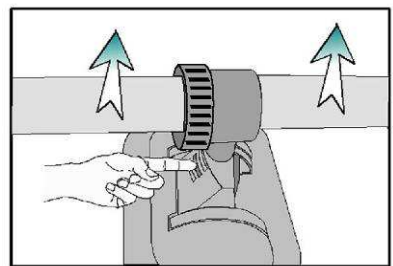
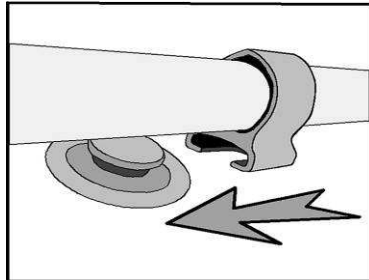
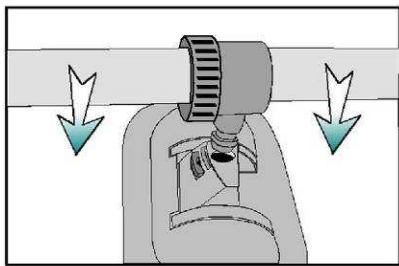
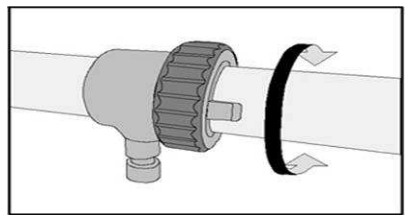
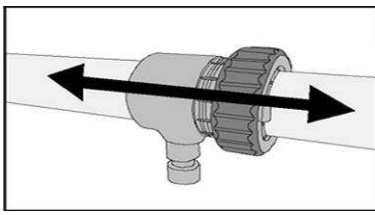
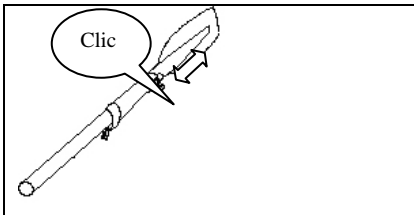
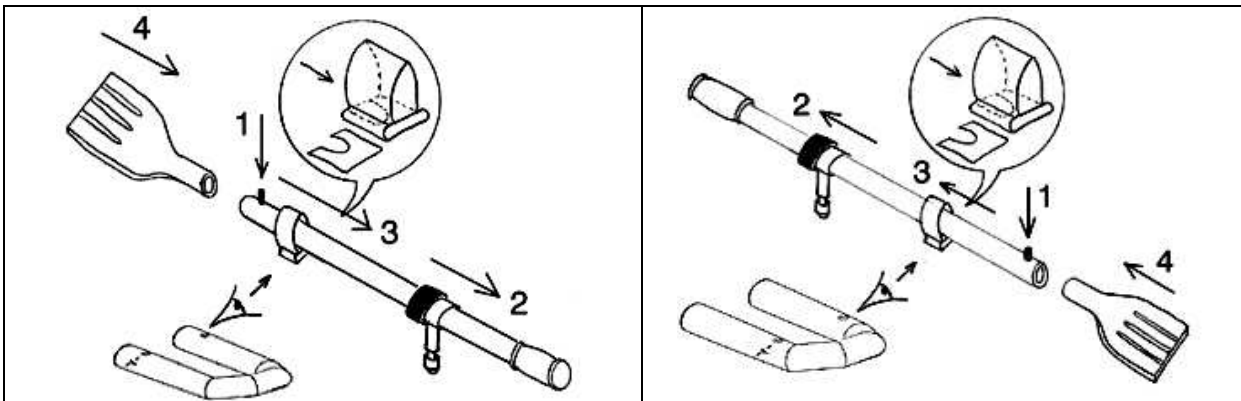

LE BANC DE NAGE

Installez le banc de nage avant de terminer le gonflage.

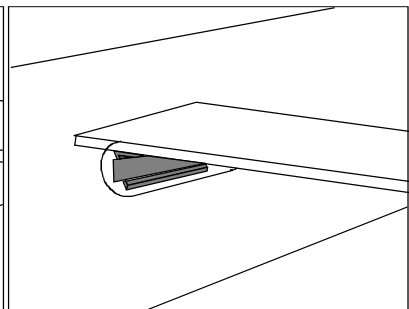
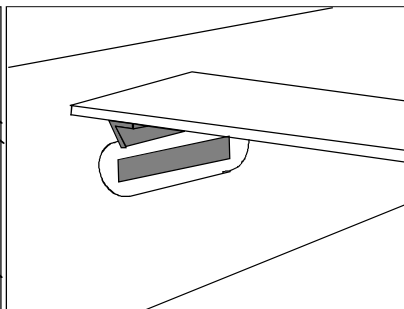
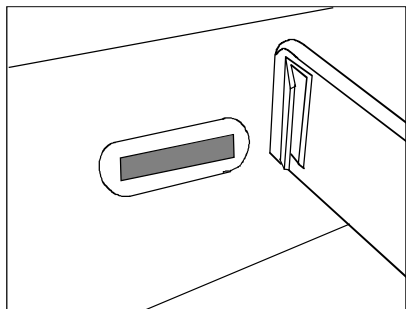

DEGONFLAGE / PLIAGE DU BATEAU

1. **Dégonflez** le bateau et remettez les protections des valves pour le stockage
2. **Retirez** les avirons (selon la procédure inverse du montage) et les éventuels équipements optionnels.
3. **Retirez** le plancher (CADET 260S, 310S, 350 S) selon la procédure inverse de celle du montage. Pour les CADET équipés de lattes ou d'un plancher gonflable, il est inutile de les retirer lors du pliage.
4. **Retirez** les bouchons des vide-vite, et **videz** le bateau de l'eau qui pourrait s'y trouver (en cas de stockage prolongé, assurez-vous que le bateau soit bien sec avant de le plier).
5. **Repliez** les 2 côtés du flotteur vers l'intérieur du bateau (A), amenez les cônes contre le tableau (B), puis enrroulez le bateau sur lui-même, autour du tableau (C). Recommencez l'opération si vous constatez qu'il reste de l'air dans les flotteurs.

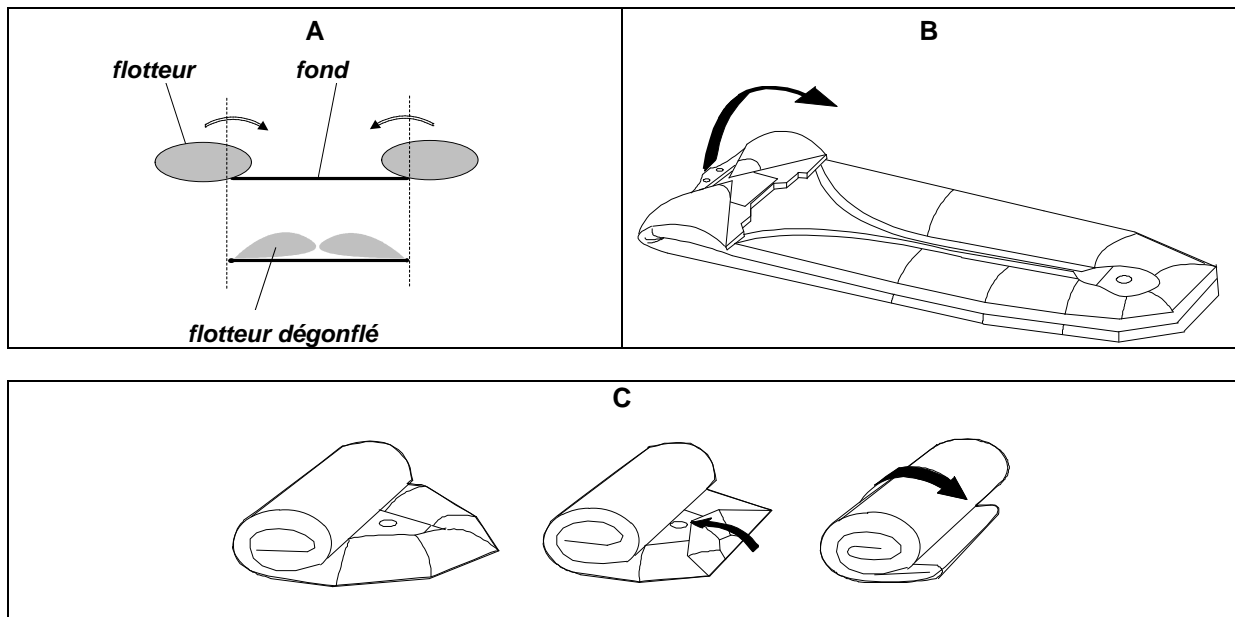

Rangez le bateau dans son sac.

Rangez le plancher rigide dans son sac (pour certains modèles à plancher bois ou aluminium).



CADET

200 Roll Up - 230 Roll Up - 270 Roll Up

200 Aero - 230 Aero - 270 Aero - 310 Aero - 350 Aero

270 ALU - 310 ALU - 350 ALU

Volume 2

VOLUME 2

TECHNICAL FEATURES - ASSEMBLY PROCEDURE



 WARNING	<ul style="list-style-type: none"> ● READ THIS MANUAL CAREFULLY BEFORE USING YOUR BOAT. ● THE OWNER'S MANUAL COMES IN TWO VOLUMES THAT SHOULD BE KEPT TOGETHER.
--------------------	---

NOTE:	<p>THE OWNER'S MANUAL IS DIVIDED INTO TWO VOLUMES:</p> <ul style="list-style-type: none"> - VOLUME 1 DEALS IN GENERAL WITH THE OPERATING PRECAUTIONS AND SAFETY RECOMMENDATIONS TO BE OBSERVED ONBOARD THE BOAT AND ON THE WATER. - VOLUME 2 DEALS WITH TECHNICAL SPECIFICATIONS AND ASSEMBLY PROCEDURE OF THE BOAT AND ITS EQUIPMENT.
--------------	---

TABLE OF CONTENTS

	Page		Page
⇒ Assembly procedure	3	⇒ Pressure	10
⇒ Check on unpacking	3	⇒ Equipment assembly	11
⇒ Boat assembly	4 - 6	⇒ Deflating / Folding the boat	12
⇒ Inflation system	7		
⇒ Inflating the boat	8 - 9	⇒ General description	I - VI

ASSEMBLY PROCEDURE

The boat assembly procedure follows an order you must respect. Proceed step by step, referring each time to the pages indicated for explanations.

PROCEDURE	PAGE	SECTION
1. Make an inventory of the parts of your boat and get to know them.	3	CHECK ON UNPACKING
	I - VI	DESCRIPTION
2. Activate the valves in the inflating position Slightly inflate the main buoyancy tube	7	INFLATION SYSTEM
	8 - 9	INFLATING THE BOAT
3. CADET Alu: Assemble the floorboard and the stringers CADET RU: Install the battens CADET AEROTEC: Inflate the floorboard.	5 - 6	BOAT ASSEMBLY
	4	
	4	
4. Install the thwart.	11	EQUIPMENT ASSEMBLY
5. fully inflate the boat to the correct pressure pressure.	8 - 9	INFLATING THE BOAT
	10	PRESSURE
6. Install the oars	11	EQUIPMENT ASSEMBLY

E
N
G
L
I
S
H

CHECK ON UNPACKING

 CAUTION	<p>DO NOT USE A SHARP TOOL (CUTTER, KNIFE, ETC.)</p>
---	---

The pack must contain 1 buoyancy tube +:

CADET	200-230-260 Roll Up	230-260 Aero	260 - 310 Solid	350 SP Alu	400 – 450 SP Alu
Battens	X				
Navy plywood floorboard			X		
Aluminium floorboard				X	X
Aerotec inflatable floorboard		X			
Inflatable keel		X	X	X	X
Stringers			X	X	X
STANDARD EQUIPMENT					
Oars	2	2	2	2	2 paddles
Inflator	1	1	1	1	1
Removable thwart	1	1	1	1	1
Bag	1	1	1	2	2
Repair kit	1	1	1	1	1
Owner's manual	2	2	2	2	2

You can equip your boat with many optional accessories (transportation wheels, ladder, lifting rings etc.). Ask your dealer to advise you.

NOTE:	<p>IF YOU WANT TO ADD LIFTING RINGS (FOR DAVIT HANDLING), YOU MUST SECURE THEM TO THE BUOYANCY TUBES, NOT ON THE FLOORBOARDS (EXCEPT FOR THE CADET 400 SR, SEE "LOCATION OF ACCESSORIES").</p>
--------------	---

BOAT ASSEMBLY



CHOOSE A SMOOTH, CLEAN SURFACE.

IF THE BUOYANCY TUBE WAS STORED AT A TEMPERATURE BELOW 0°C / 32°F, LEAVE IT AT 20°C / 68°F FOR 12 HOURS BEFORE UNFOLDING .

CADET ROLL UP – BATTEN FLOORBOARD:

If the battens are not installed, with the boat deflated, insert the battens in their brackets beginning with the batten nearest the aft transom. If a batten is difficult to insert, lubricate it with liquid soap.

CADET AERO: - INFLATABLE FLOORBOARD

high pressure floorboard DEFLATED

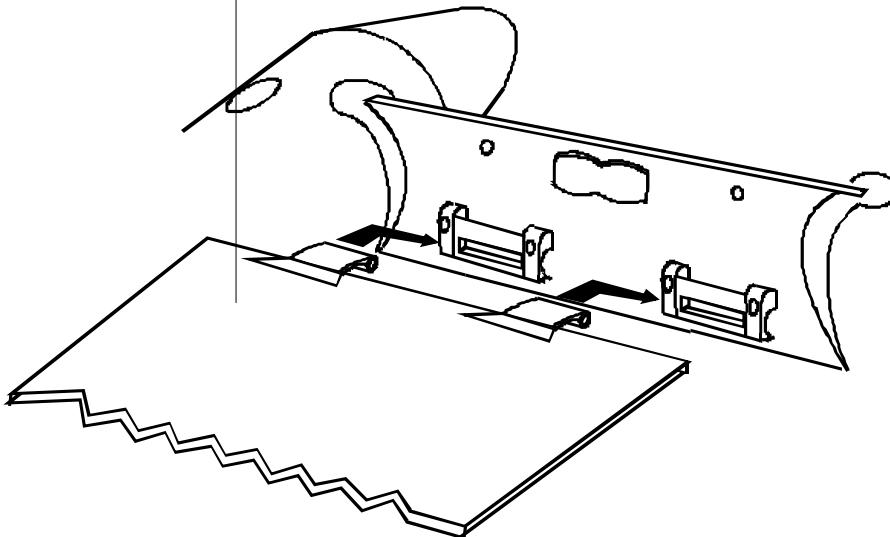

HIGH PRESSURE FLOORBOARD DISASSEMBLY/MAINTENANCE

When folding the boat, we recommend you leave the floorboard in place in the boat. However, to clean the bottom of the boat where sand and other waste may accumulate, it may be useful to remove the inflatable floorboard. Follow this procedure:

1. **DISASSEMBLY:** Deflate the buoyancy tube and the floorboard. Slide the floorboard bolt rope out of its cleats (following the assembly procedure in the reverse order).
2. **MAINTENANCE:** Slightly reinflate the boat and hose down the area between the buoyancy float and the bottom, and then lift the bow of the boat to let the water run out. Repeat the operation until all the sand or waste and has been removed.

BOAT ASSEMBLY

INSTALLING THE NAVY PLYWOOD FLOORBOARD (CADET ALUMINIUM FLOORBOARD (CADET SP ALU).

- Sprinkle some starch in the angle (reinforced strip between the buoyancy tube and the bottom, see figure 1.B) to facilitate the fitting of the floorboard.

CAUTION: NEVER USE TALCUM POWDER

- **Make sure you identify the parts and direction in which they fit:**
 - The floorboard consists of 3 main sections and 2 sections in the bow [fig. 1].
 - Identify the order of the items.
 - The bow sections have an upside and a downside. The aluminium junction sections are striped. The stripes should be visible once the parts are assembled.The stiffeners must always be on top.

1. **Slightly inflate** the buoyancy tube (this will make it easier to install the floorboard items).
2. **Insert** the bow section (1) into the bow angle.
3. **Insert** the rear section (5) against the transom (6) as show in fig 1.
4. **Fit** all the sections together [fig 1].
5. **Position** sections (3) and (4) as an apex (in a tent-like position) [fig 1 and 2].
6. **Check** that all sections are correctly aligned [fig 4].
7. **Flatten** the apex by standing on it (in the boat) and pulling the lifelines to prevent the fabric from being pinched [fig. 2].
8. **Check** that the floorboard is correctly fitted in the angles.
9. **Install** the stringers (see instructions bellow).

INSTALLING THE STRINGERS :

The stringers are essential for correct operation of the boat: they lock the floorboard together and rigidify its structure.

1. To facilitate the fitting of the first stringer (7), slide the second stringer under the bottom of the boat at about 20 cm from the side [fig. 3-a].



DO NOT PUT THE STRINGER IN POSITION UNDER THE BOAT UNTIL THE FLOOR IS FLATTENED: THEY COULD BE DAMAGED BY THE SHOCK.

2. **Position** the stringers on the edge of the floorboard. The reference mark on the stringer (8) must remain on top [fig. 3].
3. **Fit** correctly the stringers between the two buffers (9) of sections 3 and 5 [fig. 4].
4. **Rotate** the stringers so that they press against the floorboard and fit correctly in the angle [fig. 3 and 4].
5. **Because of the** self-locking system of the floorboard, the stringers will fit into place once the buoyancy tube is inflated.

BOAT ASSEMBLY

fig 1-A

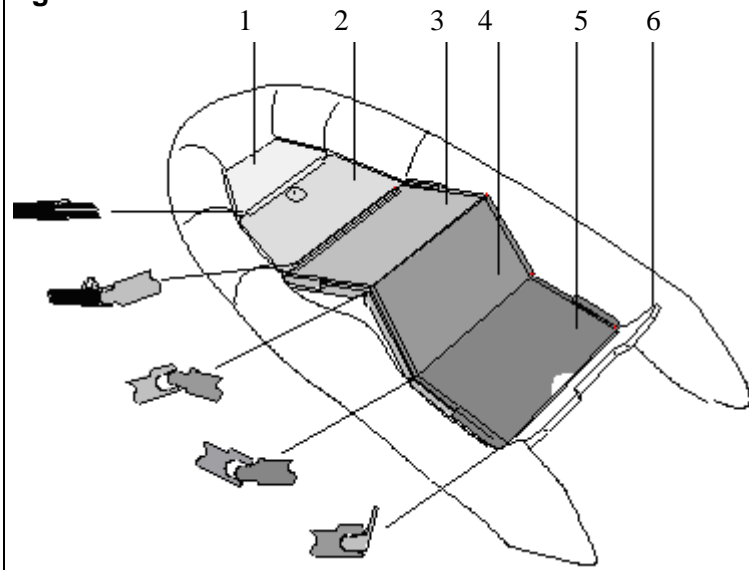

fig 1-B

- a- floorboard
- b- buoyancy tube
- c- bow angle
- d- bottom

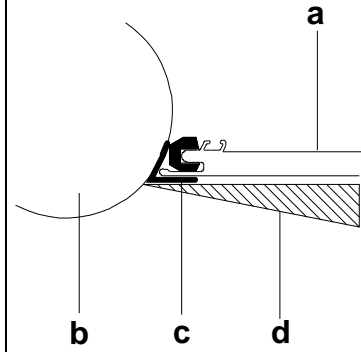

fig 2

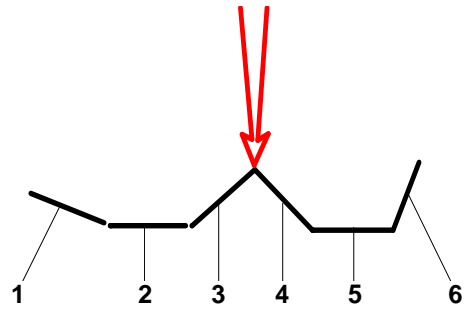
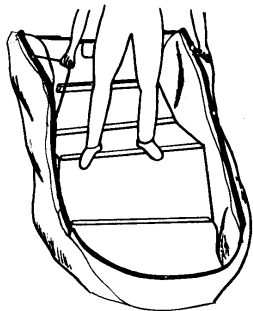

fig 3

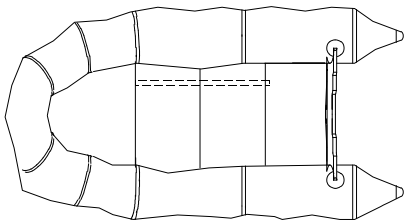
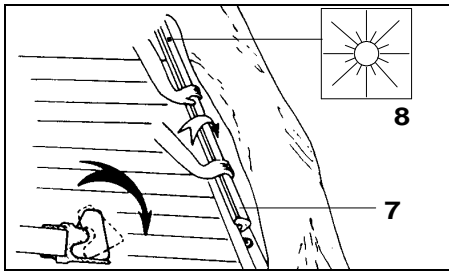
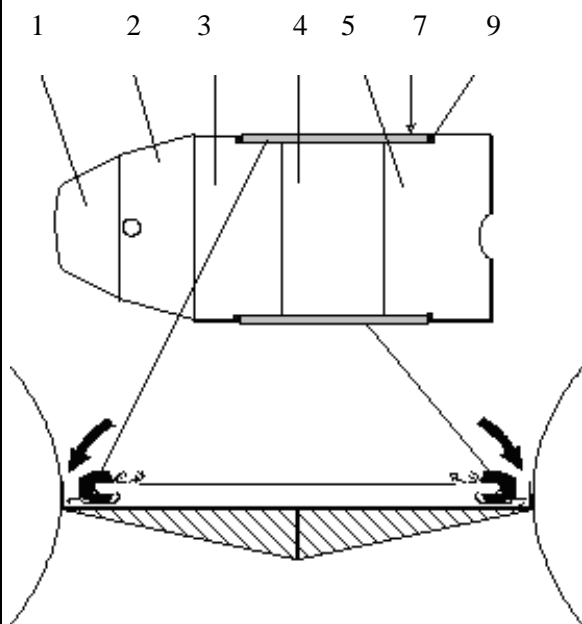

fig 4



INFLATION SYSTEM

The inflation system is composed of:

THE HIGH PRESSURE FOOT-PUMP FOR MODELS WITH AN INFLATABLE AEROTEC FLOOR

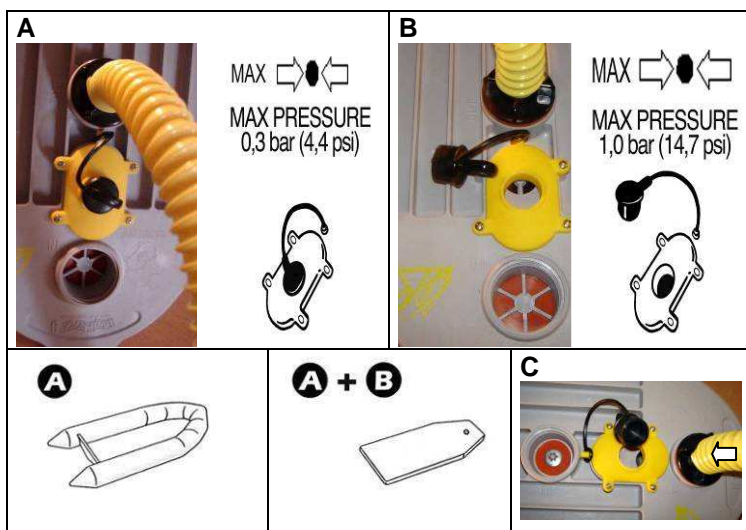

Position A

The pump has maximum flow but low pressure: this position is used to give shape rapidly to all inflatable parts of the boat.

Position B

The flow is inferior to position A, but provides pressure that is superior, with the same effort.

Position C

To deflate. Insert the tube as indicated in figure C and pump normally.

ENGLISH

THE STANDARD INFLATOR – EXCEPT FOR AEROTEC MODELS.

- A. tube nozzle
- B. tube connector
- C. inflation port

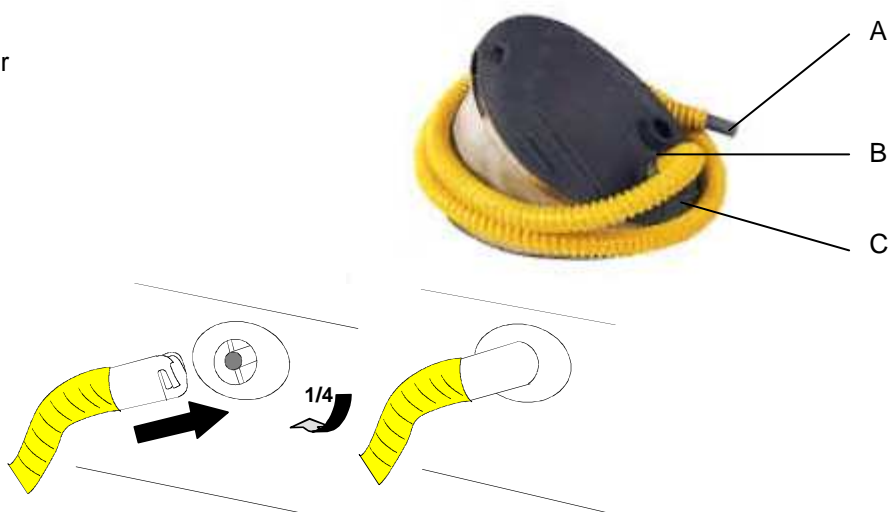

THE VALVES .

To change the position:	Inflation position	Deflation position
Push / Push	diaphragm closed, the inner button springs upwards	diaphragm open, the inner button goes down

INFLATING A NON AEROTEC BOAT (WITH BATTENS OR RIGID FLOOR)

Activate all valves in the inflation position.

Attach the hose connector to the inflator inflation port.
 To inflate your boat properly, the inflator should be correctly placed on the ground.
 The boat inflates rapidly if the inflator is used smoothly and without haste.

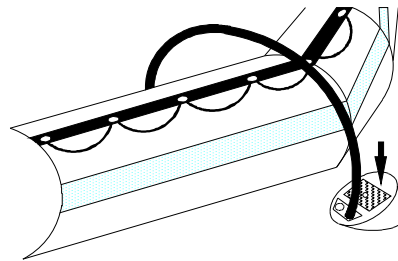





 CAUTION	<p>DO NOT USE A COMPRESSOR OR COMPRESSED AIR CYLINDER.</p>
---	---

You can use the electrical air pump *ACCESS* (ask your Dealer).

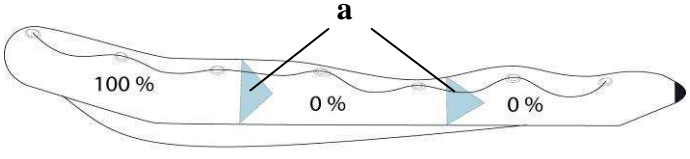
INFLATING THE BUOYANCY CHAMBER (see "PRESSURE" section)

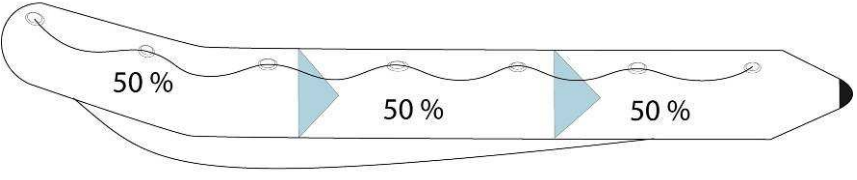
- Inflate the buoyancy mechanism, **balancing the pressure between the different compartments until the partitions (a) are no longer visible (see "PRESSURE" section)**

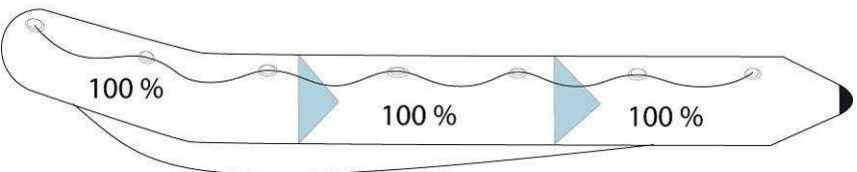
	<p>Never pressurise a compartment when the others are completely deflated</p>	
	<p>1</p>	
	<p>2</p>	

INFLATING THE KEEL (see "PRESSURE" section)

- Once the floorboard is installed, start inflation (see "PRESSURE" section)

Inflating is complete: screw on the inflating valve caps.

<p>NOTE:</p>	<p>A slight air leak is normal before the valve cap is screwed on ONLY THE VALVE CAPS CAN ENSURE FINAL AIR TIGHTNESS.</p>
---------------------	---

INFLATING A CADET AERO BOAT

Activate all valves in the inflation position.

Attach the hose connector to the inflator inflation port.

To inflate your boat properly, the inflator should be correctly placed on the ground.

The boat inflates rapidly if the inflator is used smoothly and without haste.

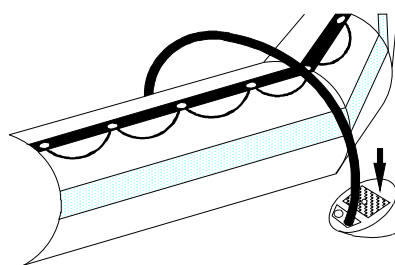

CAUTION

DO NOT USE A COMPRESSOR OR COMPRESSED AIR CYLINDER.

A - INFLATE THE HIGH PRESSURE FLOORBOARD (AEROTECH MODELS ONLY)

1. **Inflate** Insert the pipe as shown in figure A (**with the cap inserted**) and begin to inflate leaving the cap inserted. The inflator uses its full capacity. Inflate until hard.
2. Then **remove the cap**. The pump automatically uses the smallest chamber needed to provide the High Pressure bottom inflation pressure without undue force. **Complete** inflation in position B until the recommended pressure is reached (**see "PRESSURE" section**)

B - INFLATE THE MAIN BUOYANCY TUBE AND THEN THE KEEL



CAUTION

NEVER USE POSITION B TO INFLATE THE BUOYANCY TUBE OR THE KEEL: BURSTING HAZARD.

Inflate the buoyancy tube Insert the pipe as shown in figure A (**with the cap inserted**) and begin to inflate **leaving the cap inserted**. The inflator uses its full capacity and allows the recommended pressure (**see "PRESSURE" section**) to be achieved. **Make sure that the pressures between the compartments are equalized**, until the partitions (a) can no longer be seen.

	Never pressurise a compartment when the others are completely deflated	
	1	
	2	

Then inflate the keel (see "PRESSURE" section)

Inflating is complete: screw on the inflating valve caps.

NOTE:

A slight air leak is normal before the valve cap is screwed on
ONLY THE VALVE CAPS CAN ENSURE FINAL AIR TIGHTNESS.

PRESSURE

The correct pressure for the buoyancy tube and the keel is 240 mb (3.48 PSI) and the correct pressure for the Aerotech inflatable bottom is 600 mb (8.5 PSI).

If your boat is not equipped with an **ACCESS** pressure indicator, we recommend that you purchase one from your dealer. This will permit a quick and efficient control of the pressure during inflation. Without a pressure indicator, stop inflating when buoyancy tube is sufficiently hard so that the cones on the aft section of the buoyancy tube cannot be bent by hand.

The ambient temperature of the air or water proportionately influences the level of internal pressure in the buoyancy chamber

Ambient temperature	Buoyancy tube internal pressure
+1°C	+4 mb / 0.06 PSI
-1°C	-4 mb / 0.06 PSI

Thus, it is important to anticipate:

Check and adjust the pressure of the inflatable compartments (inflating or deflating according to the case) according to the temperature variations (especially when there is a considerable difference in temperature between morning and evening in particularly hot areas) and make sure that the pressure remains within the recommended pressure range (from 220 to 270 mb / green sector).

RISK OF UNDERPRESSURE

EXAMPLE: Your boat is exposed to direct sunlight on the beach (temperature=50°C) at the recommended pressure (240 mb/3.48 PSI). When you launch it (temperature=20°C), the temperature and internal pressure of the inflatable compartments will drop simultaneously (up to 120 mb) and **YOU WILL THEN NEED TO REINFLATE** until you regain the millibars lost due to the difference between the ambient air and water temperatures. A drop in pressure at the end of the day, when the outside temperature is dropping, is normal.

NOTE:

Proper inflation is critical to the performance of the boat. It is the pressure in the tubes that gives your boat the necessary rigidity to perform well. Under-inflation causes improper flexing of the tubes which will cause early aging.

RISK OF OVERPRESSURE

EXAMPLE: Your boat is inflated to its recommended pressure (240 mb/3.48 PSI) at the beginning or end of the day (low outside temperature = 10°C). Later in the day, your boat is exposed in the sun on the beach or on a yacht deck (temperature = 50°C). The temperature inside the inflatable compartments may rise to 70°C (particularly for dark buoyancy chambers), doubling the initial pressure (480 mb). **YOU WILL THEN NEED TO DEFLATE** the boat to return to the recommended pressure.



IF YOUR BOAT IS OVERINFLATED, THERE WILL BE UNDUE PRESSURE ON THE INFLATABLE STRUCTURE THAT MAY RUPTURE IT.

IN THE EVENT OF OVERPRESSURE

Deflate by pressing the spring loaded button.

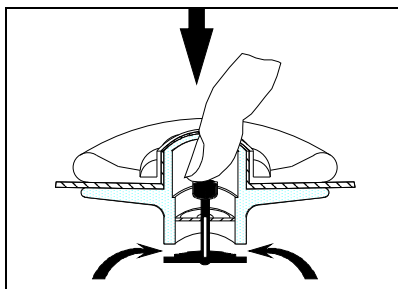

EQUIPMENT ASSEMBLY

OARS

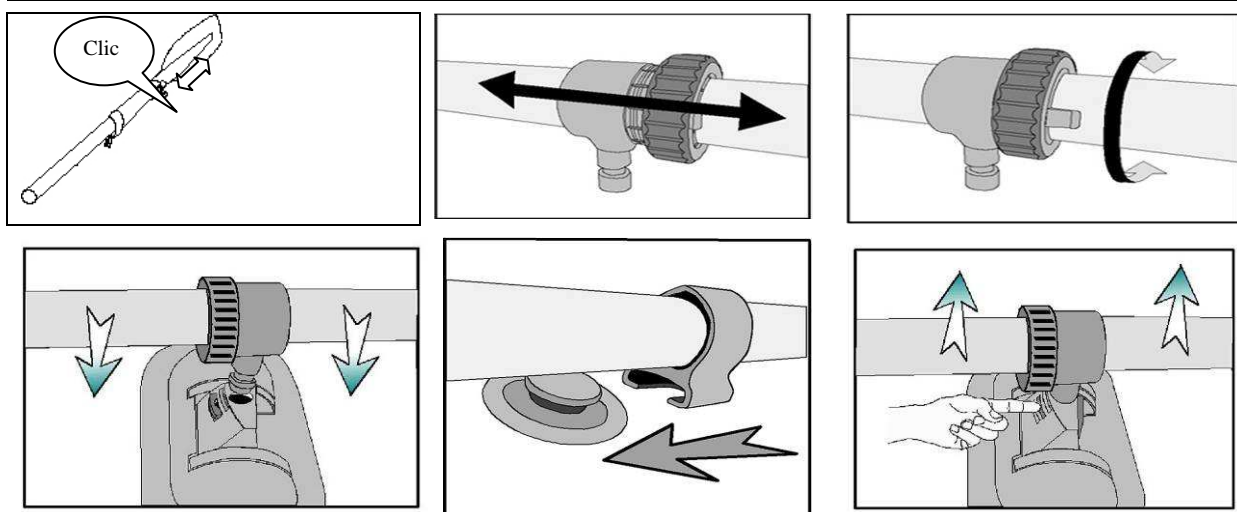
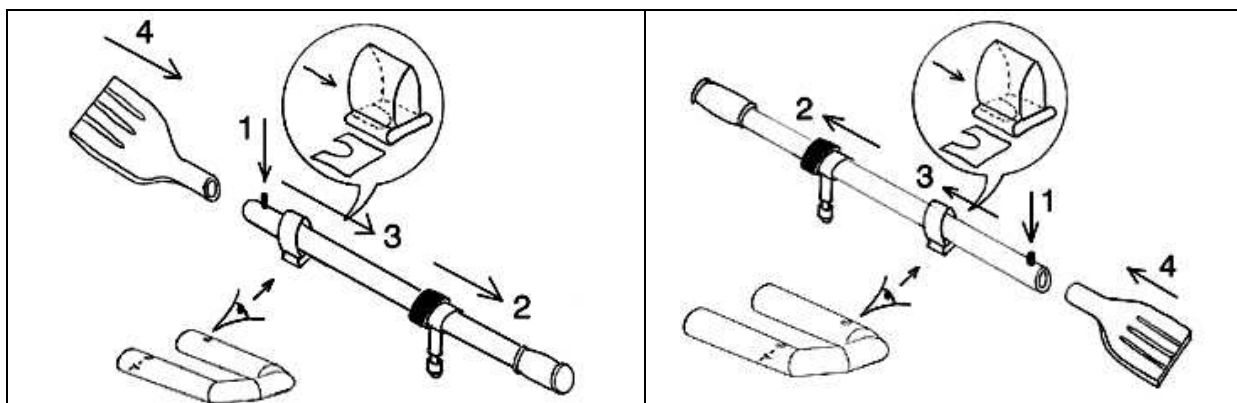

THWART

Install the thwart before completing inflation.

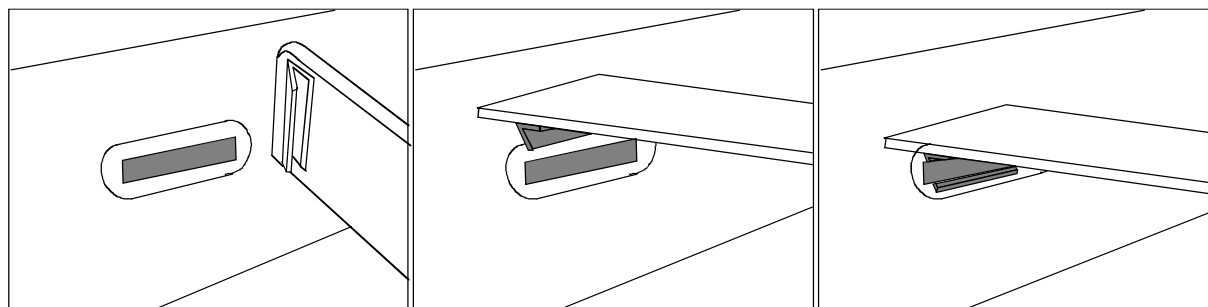

ENGLISH

DEFLATING / FOLDING THE BOAT

1. **Deflate** the boat.
2. **Replace** the valve protections.
3. **Remove** oars and equipment.
4. **Remove** the floorboard (For CADET Alu only - for models with a slatted floor, It is not necessary to remove the slats to fold the boat).
5. **Empty** the boat of all water and sand by opening the self-bailers, dry it.
6. **Fold in** the 2 sides of the main buoyancy tube (A), fold the cones onto the transom, then **roll up** the boat around the transom (C). Start again if you feel there is still some air left in the tubes.

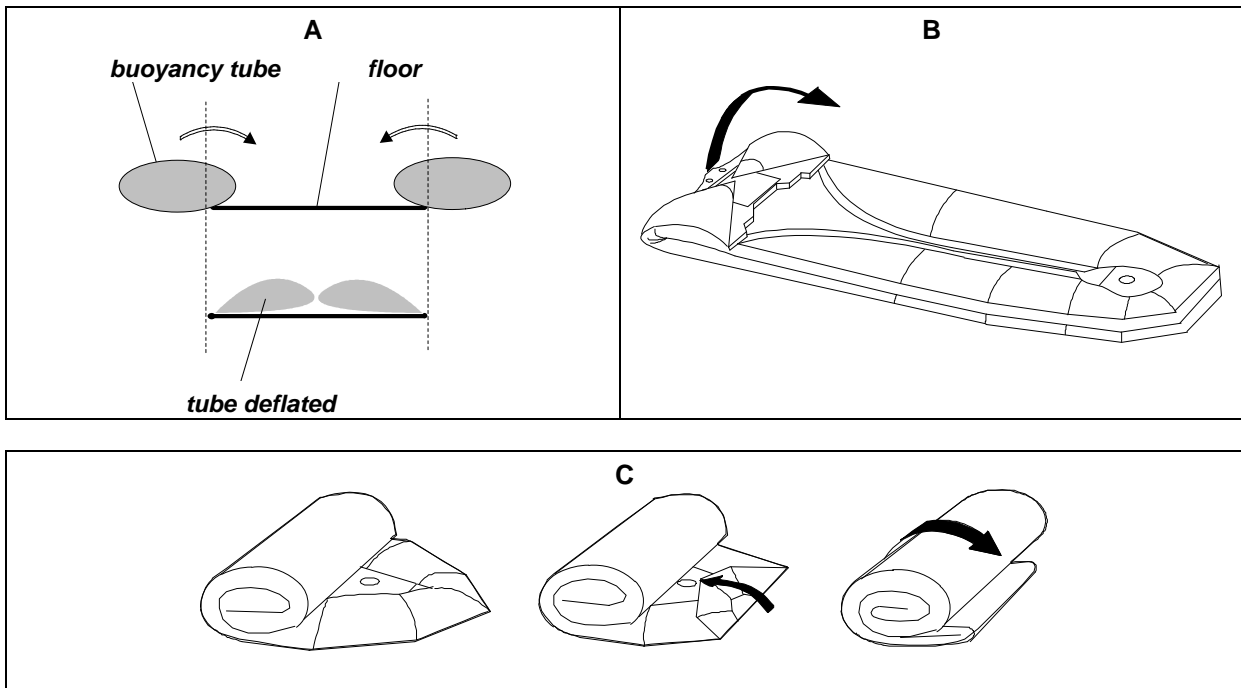

Stow the boat in its bag.

For some models with wooden or aluminium floorboard, **stow** the floorboard in its bag.



CADET

200 Roll Up - 230 Roll Up - 270 Roll Up

200 Aero - 230 Aero - 270 Aero - 310 Aero - 350 Aero

270 ALU - 310 ALU - 350 ALU

Tomo 2

Volume 2

CARATTERISTICHE TECNICHE – PROCEDURE DI MONTAGGIO



 AVVERTENZA	<ul style="list-style-type: none">● LEGGERE ATTENTAMENTE IL PRESENTE MANUALE PRIMA DI UTILIZZARE L'IMBARCAZIONE.● IL MANUALE DEL PROPRIETARIO SI COMPONE DI DUE TOMI CHE DEVONO ESSERE CONSERVATI INSIEME.
--	---

NOTA:	<p>IL MANUALE DEL PROPRIETARIO SI COMPONE DI DUE VOLUMI:</p> <p>- VOLUME 1 RIGUARDA IN GENERALE LE PRECAUZIONI D'USO E LE RACCOMANDAZIONI DA RISPETTARE A BORDO DELL'IMBARCAZIONE E DURANTE LA NAVIGAZIONE.</p> <p>- VOLUME 2 RIGUARDA PIÙ PARTICOLARMENTE LE CARATTERISTICHE TECNICHE E DI MONTAGGIO DELL'IMBARCAZIONE E DEL SUO EQUIPAGGIAMENTO.</p>
--------------	---

INDICE

	PAG.		PAG.
⇒ Procedura generale per la messa in servizio dell'imbarcazione	3	⇒ Pressione	10
⇒ Inventario all'apertura dell'imballaggio	3	⇒ Assemblaggio dell'equipaggiamento	11
⇒ Montaggio dell'imbarcazione	4 - 6	⇒ Sgonfiaggio / piegatura dell'imbarcazione	12
⇒ Il sistema di gonfiaggio	7		
⇒ Gonfiaggio dell'imbarcazione	8 - 9	⇒ Descrizione generale	I - VI

PROCEDURA GENERALE PER LA MESSA IN SERVIZIO DELL'IMBARCAZIONE

La procedura di montaggio dell'imbarcazione segue un ordine preciso che si consiglia caldamente di rispettare. Procedere tappa dopo tappa, consultando ogni volta le pagine indicate per la spiegazione della procedura.

PROCEDURA	PAG.	SEZIONE
1. Effettuare l'inventario degli elementi che compongono l'imbarcazione e imparare a riconoscerli.	3	INVENTARIO ALL'APERTURA
	I - VI	DESCRIZIONE
2. Portare le valvole in posizione di gonfiaggio Gonfiare leggermente il galleggiante.	7	SISTEMA DI GONFIAGGIO
	8 - 9	GONFIAGGIO DEL BATTELLO
3. CADET Alu : Assemblare il piano e i longheroni. CADET Roll Up : Montare le doghe. CADET Aero : Gonfiare il piano.	5 - 6	MONTAGGIO DEL BATTELLO
	4	
	4	
4. Installare il banco di voga.	11	MONTAGGIO DELL'APPARECCHIATURA
5. Terminare il gonfiaggio dell'imbarcazione alle pressioni di utilizzo.	8 - 9	GONFIAGGIO DEL BATTELLO
	10	PRESSIONE
6. Collocare i remi.	11	MONTAGGIO DELL'APPARECCHIATURA

INVENTARIO ALL'APERTURA DELL'IMBALLAGGIO

 ATTENZIONE	NON UTILIZZARE STRUMENTI TAGLIANTI (TAGLIERINE, COLTELLI, ECC.)
--	--

L'imballaggio dell'imbarcazione contiene 1 galleggiante e i seguenti elementi:

CADET	200-230-270 Roll Up	200-230 Aero	270-310 Aero	270-310-350 Alu
Doghe	X			
Piano in alluminio				X
Piano gonfiabile AEROTEC		X	X	
Chiglia gonfiabile			X	X
Longheroni			X	X
Equipaggiamento standard				
Remi	2	2	2	2
Pompa di gonfiaggio	1	1	1	1
Banco di voga amovibile	1	1	1	1
Sacca di trasporto	1	1	1	1
Valigetta per le riparazioni	1	1	1	1
Manuale dell'utente	2	2	2	2

E' possibile aggiungere all'imbarcazione degli accessori supplementari (ruote di trasporto, scaletta, anelli di sollevamento, ecc.). Chiedere consiglio al proprio rivenditore.

NOTA:	IN CASO DI AGGIUNTA DI ANELLI DI SOLLEVAMENTO (PER LA MESSA SOTTO PARANCHI) E' FONDAMENTALE CHE ESSI VENGANO FISSATI SUI GALLEGGIANTI E NON SUL PIANO (TRANNE 400SR, VEDERE "POSIZIONAMENTO ACCESSORI").
--------------	---

MONTAGGIO DELL'IMBARCAZIONE



PROCEDERE AL MONTAGGIO SU UN SUPPORTO PULITO E LISCIO.
SE IL TUBOLARE È STATO CONSERVATO A UNA TEMPERATURA INFERIORE A 0°C, LASCIARLO PER 12 ORE IN UN LUOGO TEMPERATO (20°C) PRIMA DI PROCEDERE AL MONTAGGIO.

CADET – PIANO CON LE DOGHE

Con l'imbarcazione sgonfia, infilare le doghe nei loro supporti iniziando con la doga più vicina al quadro di poppa. Se l'inserimento di una doga risulta difficile, lubrificarla con del sapone liquido.

CADET AERO: PIANO GONFIABILE AEROTEC

Piano ad Alta Pressione SGONFIO

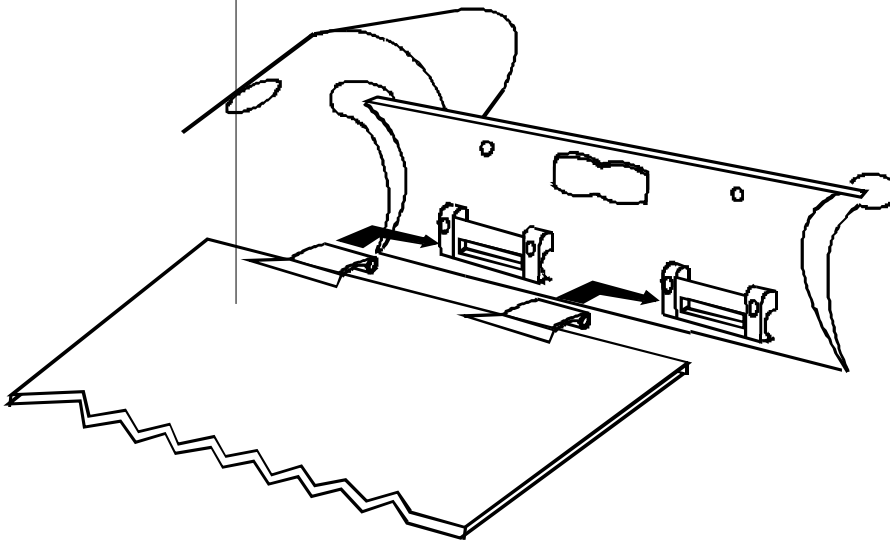

SMONTAGGIO / MANUTENZIONE DEL PIANO GONFIABILE AD ALTA PRESSIONE

Quando lo si ripiega, si consiglia di lasciare il piano al proprio posto nell'imbarcazione. Per pulire il fondo dell'imbarcazione dove possono accumularsi sabbia e altri detriti, può in ogni caso essere utile togliere il piano gonfiabile. Procedere quindi nel modo che segue:

1. **SMONTAGGIO:** Sgonfiare il galleggiante e il piano.
Far scivolare la ralinga del piano fuori dalle sue galloccie (procedura inversa rispetto a quella del montaggio).
2. **MANUTENZIONE:** Rigonfiare leggermente l'imbarcazione prima di risciacquarla a getto tra il galleggiante e il fondo, quindi togliere il muso per far defluire l'acqua. Ripetere l'operazione sino all'eliminazione completa di tutta la sabbia e dei detriti.

CADET SOLID / CADET SP ALU - COLLOCAZIONE DEL PIANO CON PANNELLO IN COMPENSATO AD USO ESTERNO O IN ALLUMINIO..

- Mettere un po' di fecola di patate nell'angolare (banda rinforzata situata tra il galleggiante e il fondo, vedere Figura 1.B) per facilitare la collocazione degli elementi del piano.

ATTENZIONE: NON USARE MAI TALCO

- **Individuare gli elementi e il loro senso:**
 - Il piano è composto da tre elementi di piano e da due alette anteriori [Fig. 1].
 - Localizzare l'ordine degli elementi.
 - Le alette hanno un lato dritto ed un lato rovescio. Orientarsi con le righe dei profilati di alluminio di giunzione: devono essere visibili una volta che gli elementi sono stati montati. I rinforzi devono sempre trovarsi sul lato rivolto verso l'alto.

1. **Gonfiare** leggermente il galleggiante (questo faciliterà la collocazione degli elementi del piano).
2. **Introdurre** l'aletta davanti (1) nell'angolare.
3. **Introdurre** l'elemento dietro (5) contro il quadro (6) come indicato in Figura 1.
4. **Incastrare** gli elementi gli uni negli altri [Fig.1].
5. **Mettere a "tetto"** gli elementi del piano (3) e (4) [Fig 1 e 2].
6. **Verificare** che l'insieme sia correttamente allineato [Fig 4].
7. **Appiattare** il tetto salendo nell'imbarcazione e tirando le rizze verso l'alto per evitare che il tessuto si incastri [Fig. 2].
8. **Verificare** che il piano sia correttamente posizionato nell'angolare.
9. **Installare** i longheroni come indicato poco oltre.

POSIZIONAMENTO DEI LONGHERONI

I longheroni permettono di bloccare il piano e di irrigidirne la struttura, elemento essenziale per una buona navigabilità dell'imbarcazione.

1. Per facilitare la collocazione del primo longherone (7), far scivolare il secondo longherone sotto il fondo dell'imbarcazione a 20 centimetri circa dal bordo [Fig. 3].



NON COLLOCARE IL LONGHERONE SOTTO IL FONDO DELL'IMBARCAZIONE PRIMA DI AVERE APPIATTITO IL PIANO: IL COLPO POTREBBE DANNEGGIARLO.

2. **Posizionare** i longheroni lungo il piano. Il longherone (8) deve rimanere sul lato rivolto verso l'alto [Fig. 3].
3. **Accertarsi** che i longheroni siano correttamente posizionati tra i paracolpi (9) degli elementi 3 e 5 [Fig. 4].
4. **Far ruotare** i longheroni su se stessi in modo tale che prendano "a sandwich" lo spessore del piano e si posizionino correttamente nell'incavo dell'angolare [Fig. 3 e 4].
5. **La struttura** autoserrante del piano facilita la collocazione finale dei longheroni al momento del gonfiaggio del galleggiante.

MONTAGGIO DELL'IMBARCAZIONE

Fig. 1-A

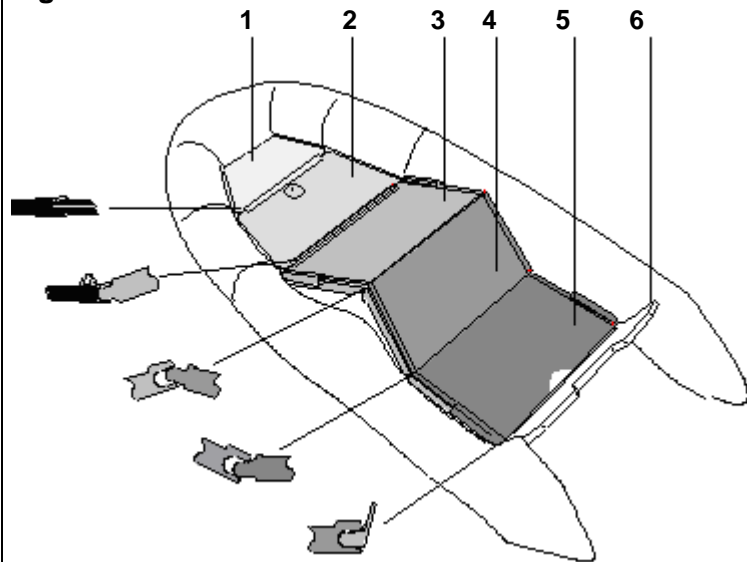

Fig. 1-B

a - piano b - galleggiante
c - angolare d - fondo

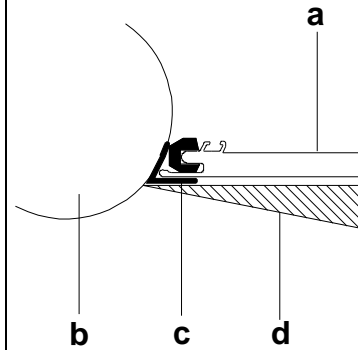

Fig. 2

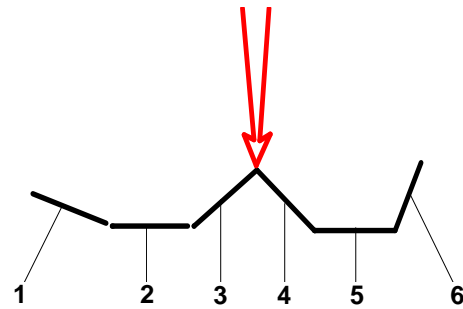
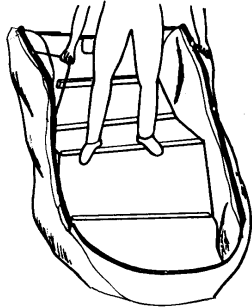

Fig. 3

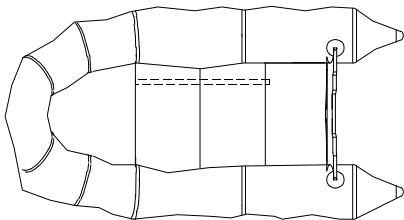
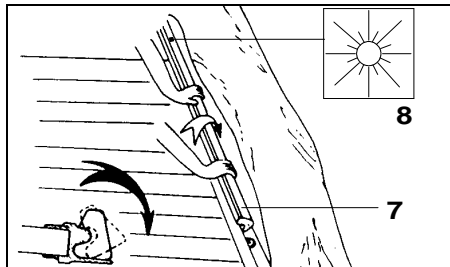
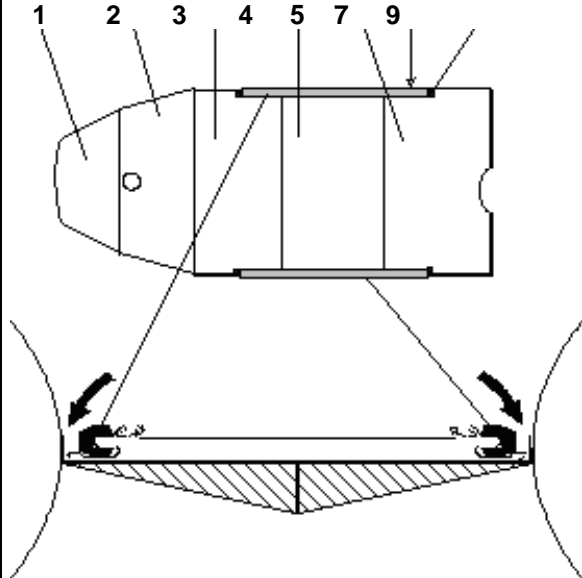

Fig. 4



SISTEMA DI GONFIAGGIO

Il sistema di gonfiaggio comprende:

IL GONFIATORE HP

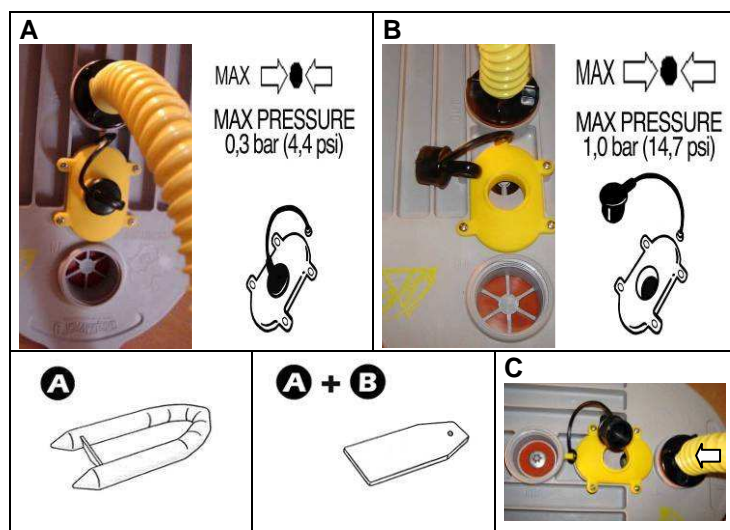

In posizione A: (Lasciare inserito il tappo) Il gonfiatore ha una portata massima con una pressione bassa: in questa posizione si gonfiano rapidamente tutti gli elementi

In posizione B: (rimuove il tappo) Il gonfiatore ha una portata inferiore rispetto alla posizione A, ma consente di raggiungere una pressione superiore

In posizione C: per sgonfiare. Innestare il tubo come indicato nella fig. C e pompare normalmente.

POMPA STANDARD

- A. punta del tubo
- B. base del tubo
- C. orifizio di gonfiaggio

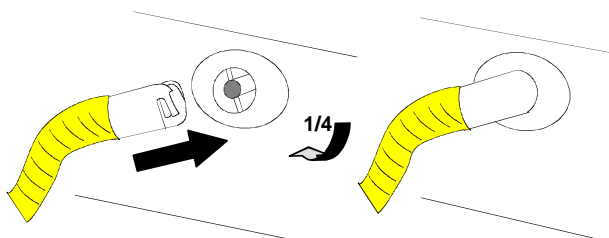
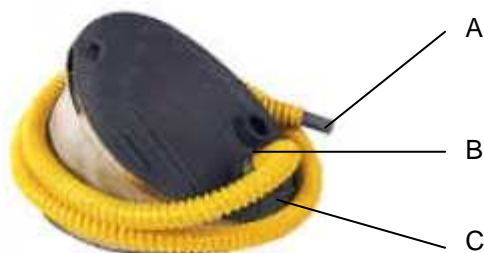

LE VALVOLE

Per attivare le valvole a scomparsa	in posizione di gonfiaggio	in posizione di sgonfiaggio
Spingere la membrana	La membrana è bloccata in posizione di gonfiaggio	La membrana è bloccata in posizione di sgonfiaggio

ITALIANO

GONFIAGGIO DELL'IMBARCAZIONE NON AERO

Predisporre tutte le valvole in posizione di gonfiaggio.

Fissare la base del tubo all'orifizio di gonfiaggio della pompa.

Per gonfiare correttamente il battello, occorre che la pompa abbia un assetto stabile a terra.

Il battello si gonfia rapidamente se la pompa è azionata delicatamente e senza precipitazione.

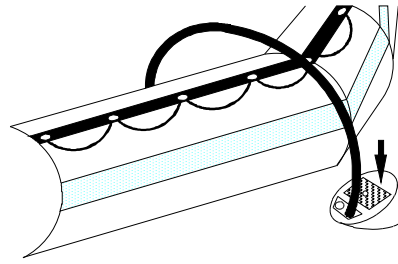





 ATTENZIONE	NON UTILIZZARE COMPRESSORI O BOMBOLE AD ARIA COMPRESSA.
--	--

E' possibile utilizzare la pompa elettrica ACCESS in vendita presso i rivenditori autorizzati.

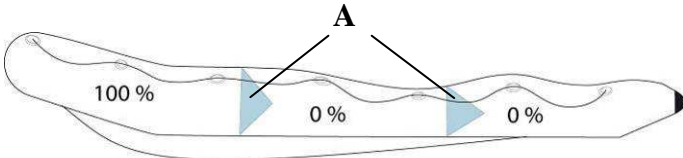
GONFIAGGIO DEL TUBOLARE (vedere sezione **PRESSIONE**)

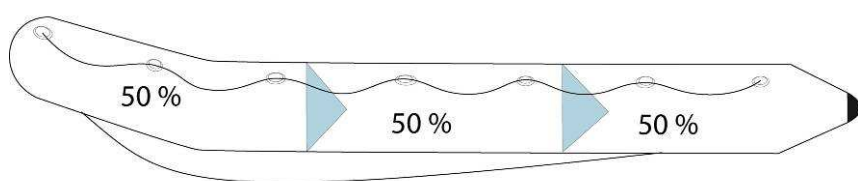
- Procedere al gonfiaggio del tubolare **equilibrando le pressioni tra i diversi compartimenti, finché i compartimenti stagni (a) non siano più visibili (pressione = vedere sezione **PRESSIONE**)**

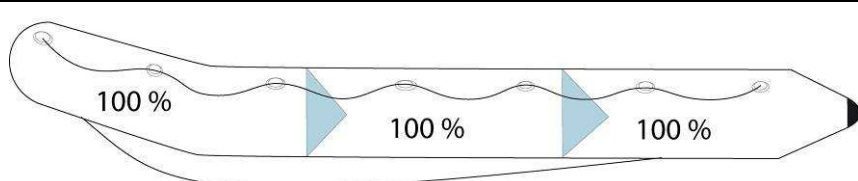
	Non mettere mai un compartimento sotto pressione se gli altri sono completamente sgonfi	
	1	
	2	

GONFIAGGIO DELLA CHIGLIA (vedere sezione **PRESSIONE**)

- **Una volta montato il piano, procedere al gonfiaggio (vedere sezione **PRESSIONE**).**

Una volta terminato il gonfiaggio: Avvitare i tappi delle valvole di gonfiaggio.

NOTA:	È normale una leggera perdita d'aria prima di avvitare i tappi delle valvole. SOLO I TAPPI GARANTISCONO L'ERMETICITÀ FINALE.
--------------	--

GONFIAGGIO DELL'IMBARCAZIONE CADET AERO

Predisporre tutte le valvole in posizione di gonfiaggio.

Fissare la base del tubo all'orifizio di gonfiaggio della pompa.

Per gonfiare correttamente il battello, occorre che la pompa abbia un assetto stabile a terra.

Il battello si gonfia rapidamente se la pompa è azionata delicatamente e senza precipitazione.

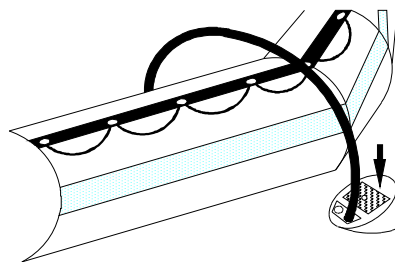

 ATTENZIONE	NON UTILIZZARE COMPRESSORI O BOMBOLE AD ARIA COMPRESSA.
--	--





A – GONFIARE IL PIANO AD ALTA PRESSIONE (SOLO MODELLI AEROTEC)

1. **Gonfiare.** Inserire il tubo come indicato nella Figura A e iniziare a gonfiare lasciando il **tappo inserito**. La pompa sfrutta completamente la propria capacità. Gonfiare sino all'indurimento della parte.
2. Quindi **togliere il tappo**. La pompa utilizza automaticamente una camera più piccola che permette di raggiungere senza sforzo la pressione di gonfiaggio del fondo ad Alta Pressione. Terminare il gonfiaggio in posizione B sino a raggiungere la pressione raccomandata (**vedere sezione PRESSIONE**)

B – GONFIARE IL GALLEGGIANTE PRINCIPALE QUINDI LA CHIGLIA

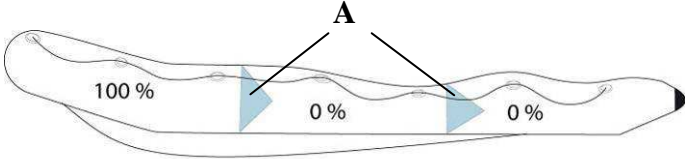
 ATTENZIONE	NON UTILIZZARE MAI LA POSIZIONE B PER GONFIARE IL GALLEGGIANTE O LA CHIGLIA: SI RISCHIA L'ESPLOSIONE!
--	--

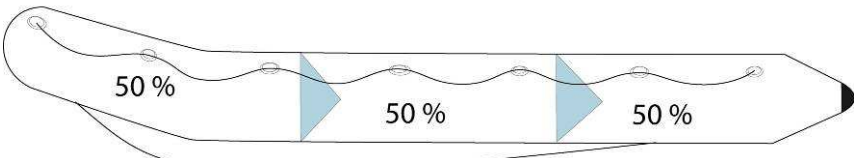
Gonfiare il galleggiante. Inserire il tubo come indicato nella Figura A e iniziare a gonfiare lasciando il **tappo inserito**. La pompa sfrutta completamente la propria capacità e permette di raggiungere la pressione raccomandata (**vedere sezione PRESSIONE**). **Accertarsi che si bilancino le pressioni tra i diversi scomparti**, fino a quando i tramezzi (a) non sono più visibili.

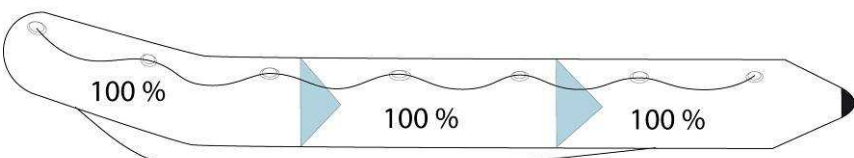
	Non mettere mai un compartimento sotto pressione se gli altri sono completamente sgonfi	
	1	
	2	

Una volta terminato il gonfiaggio: Avvitare i tappi delle valvole di gonfiaggio.

NOTA:	E' normale che si produca una leggera fuoriuscita d'aria prima di avvitare il tappo. SOLO I TAPPI GARANTISCONO L'ERMETICITÀ FINALE.
--------------	---

I
T
A
L
I
A
N
O

PRESSIONE

La pressione di utilizzo per il galleggiante e la chiglia è di 240 mb (3,48 PSI); quella del fondo gonfiabile Aerotec è di 600 mb (8.5 PSI).

Se l'imbarcazione non è provvista di un indicatore di pressione **ACCESS**, si raccomanda di procurarsene uno: esso permette infatti una lettura rapida ed efficace durante il gonfiaggio. In assenza dell'indicatore di pressione, arrestare il gonfiaggio non appena il galleggiante è sufficientemente rigido da non poter più essere possibile piegare con le mani i coni dietro al galleggiante.

La temperatura ambiente dell'aria o

dell'acqua influisce in modo proporzionale sul livello della pressione interna del tubolare

Temperatura ambiente	Pressione interna del tubolare
+1°C	+4 mb / 0,06 PSI
-1°C	-4 mb / 0,06 PSI

Inoltre, è importante saper anticipare:

Verificare e regolare la pressione dei compartimenti gonfiabili (rigonfiando o sgonfiando, a seconda dei casi) in funzione delle variazioni di temperatura (soprattutto quando gli sbalzi sono importanti tra la mattina e la sera, nelle zone particolarmente calde) ed accertarsi che la pressione non sia troppo diversa rispetto a quella raccomandata (da 220 a 270 mb / zona verde).

RISCHIO DI SOTTOPRESSIONE

ESEMPIO: Il battello è esposto ai raggi diretti del sole sulla spiaggia (temperatura = 50°C) ad una pressione raccomandata (240 mb/3,48 PSI). Dopo aver messo l'imbarcazione in acqua (temperatura = 20°C), la temperatura e la pressione interne dei compartimenti gonfiabili diminuiscono (fino a 120 mb). **SARÀ NECESSARIO RIGONFIARLI** fino a recuperare i millibar perduti a causa degli sbalzi di temperatura tra l'aria e l'acqua. Pertanto, è normale constatare una diminuzione di pressione alla fine della giornata, quando la temperatura si abbassa.

NOTA:

Qualora non fosse completamente gonfiata, l'imbarcazione risulterà poco rigida durante la navigazione, offrirà cattive prestazioni e rischierà di invecchiare precocemente.

RISCHIO DI SOVRAPRESSIONE

ESEMPIO: Il battello è gonfiato alla pressione consigliata (240 mb/3,48 PSI) all'inizio o alla fine della giornata (temperatura ambiente bassa = 10°C). Più tardi, l'imbarcazione è esposta alla luce diretta del sole sulla spiaggia o sul ponte di uno yacht (temperatura = 50°C) La temperatura interna di tutti i compartimenti interni può allora aumentare e raggiungere i 70°C (soprattutto se i tubolari sono di colore scuro). La pressione raddoppierà (480 mb). **OCCORRE DUNQUE SGONFIARE I TUBOLARI** per ottenere di nuovo la pressione raccomandata.



ATTENZIONE

SE IL BATTELO È TROPO GONFIO, LA PRESSIONE SOLLECITA LA STRUTTURA GONFIABILE IN MODO ANOMALO E SI PUÒ VERIFICARE UNA ROTTURA DEL TESSUTO.

IN CASO DI SOVRAPRESSIONE

Liberare l'aria spingendo il frutto interno della valvola

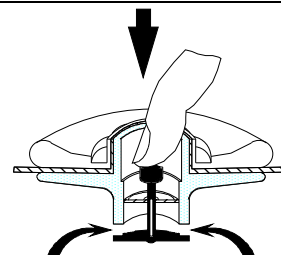

- **PRESSIONE INSUFFICIENTE:** gonfiare

ASSEMBLAGGIO DELL'EQUIPAGGIAMENTO

I REMI

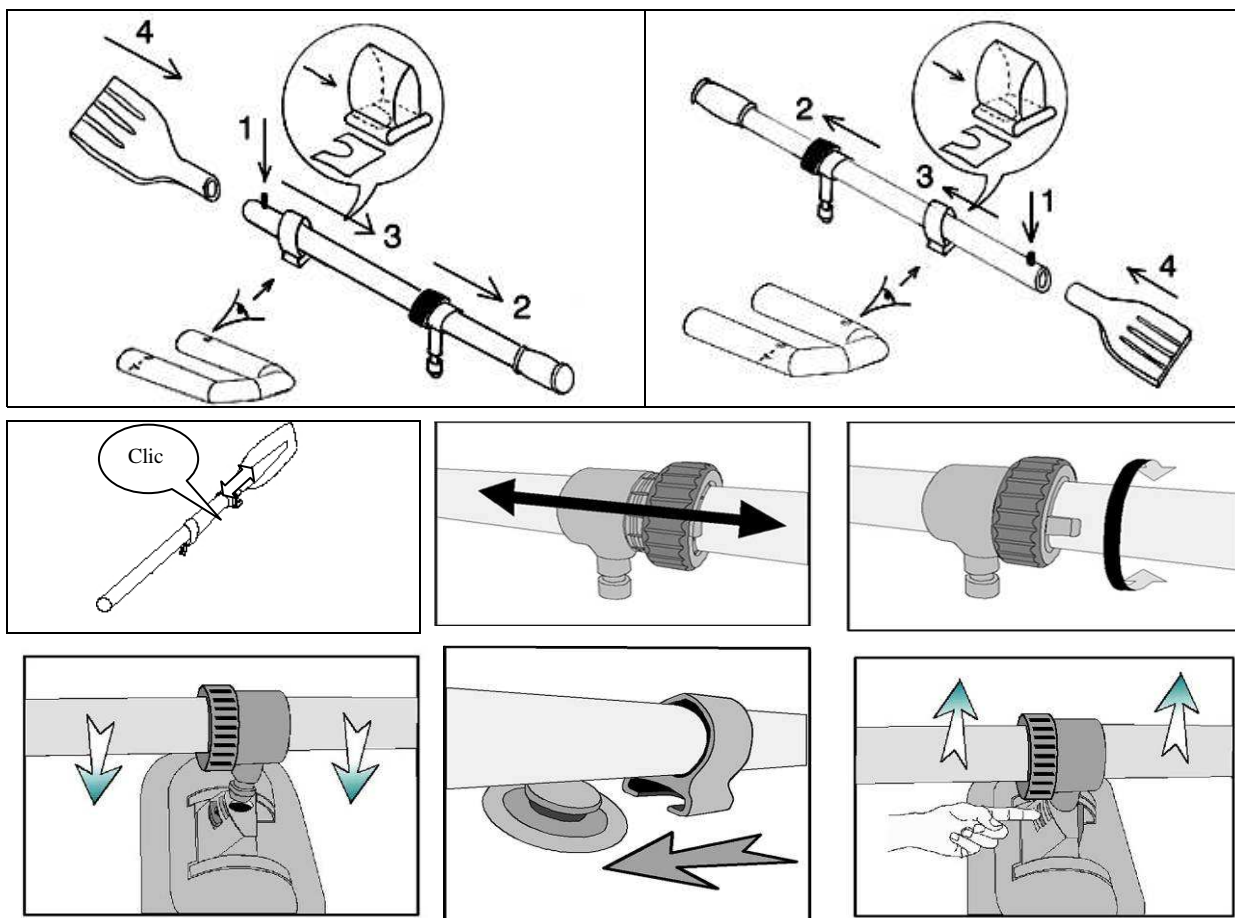

ITALIANO

IL BANCO DI VOGA

Installare il banco di voga prima di terminare il gonfiaggio.

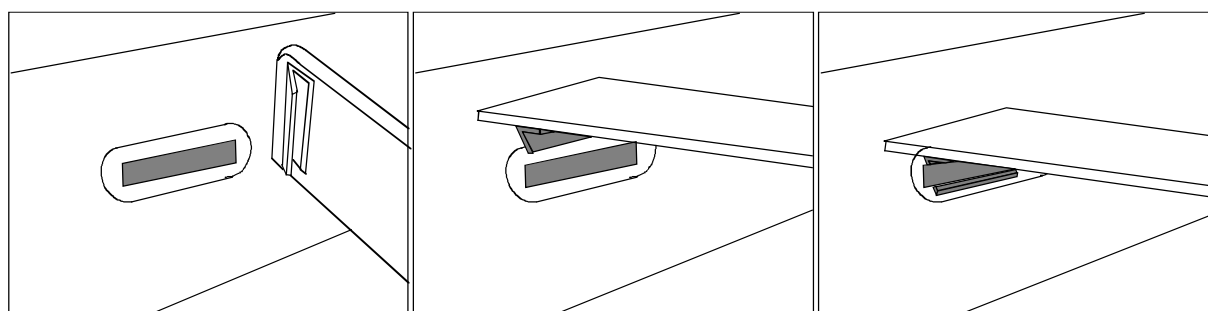

SGONFIAGGIO / PIEGATURA DELL'IMBARCAZIONE

1. **Sgonfiare** l'imbarcazione e rimettere le protezioni delle valvole per lo stoccaggio.
2. **Togliere** i remi (procedura opposta rispetto al montaggio) e le eventuali apparecchiature opzionali.
3. **Togliere** il piano (CADET ALU) eseguendo la procedura inversa rispetto a quella del montaggio. Per gli CADET provvisti di doghe, si ricorda che è inutile toglierle quando si ripiega l'imbarcazione.
4. **Togliere** i tappi delle valvole di scarico rapido e **svuotare** l'imbarcazione dall'acqua eventualmente rimasta al suo interno (nel caso in cui l'imbarcazione venga riposta per un lungo periodo di tempo, accertarsi che sia perfettamente asciutta prima di ripiegarla).
5. **Piegare** i due lati del galleggiante verso la parte interna dell'imbarcazione (A), portare i coni contro il quadro (B), quindi arrotolare l'imbarcazione su se stessa, attorno al quadro (C). Ripetere l'operazione in presenza di aria rimasta nei galleggianti.

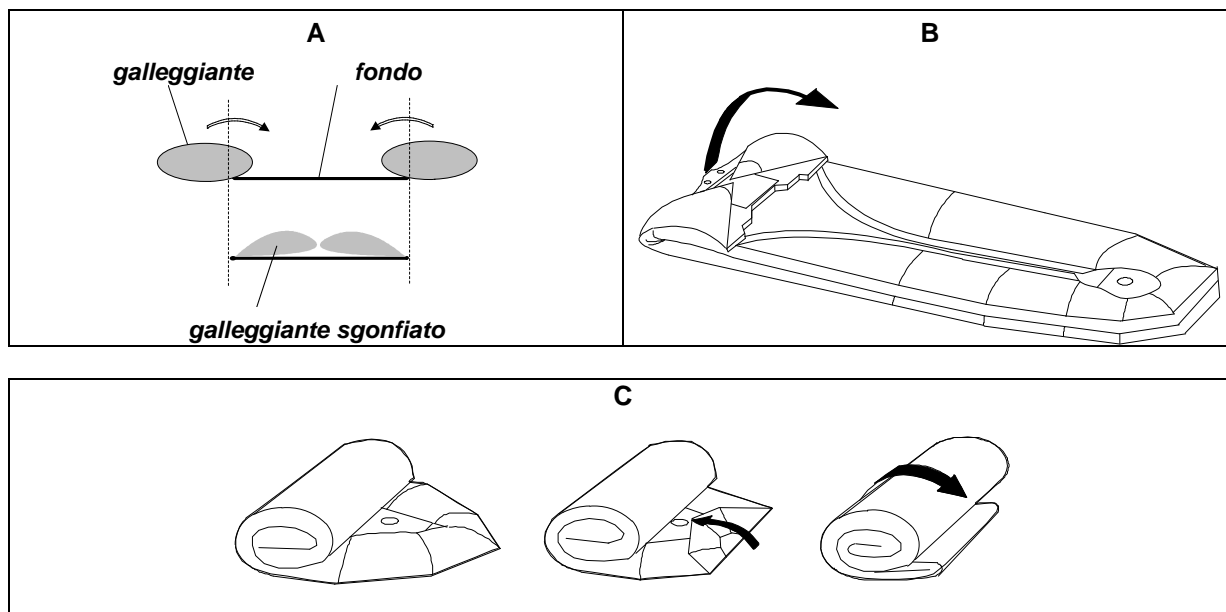

Rimessare il battello nelle apposite sacche.



CADET

200 Roll Up - 230 Roll Up - 270 Roll Up

200 Aero - 230 Aero - 270 Aero - 310 Aero - 350 Aero

270 ALU - 310 ALU - 350 ALU

Teil 2

Band 2 TECHNISCHE DATEN - MONTAGEVERFAHREN



 WARNHINWEIS	<ul style="list-style-type: none"> ● VOR INBETRIEBNAHME IHRES BOOTES LESEN SIE DIESES HANDBUCH SORGFÄLTIG DURCH. ● DAS EIGNERHANDBUCH BESTEHT AUS ZWEI BÄNDEN, DIE ZUSAMMEN AUFBEWAHRT WERDEN MÜSSEN.
---	---

HINWEIS	<p>DAS EIGNERHANDBUCH BESTEHT AUS ZWEI BÄNDEN:</p> <ul style="list-style-type: none"> - BAND 1 BEHADELT DIE AM BORD UND AUF WASSER ZU BEACHTENDEN ALLGEMEINEN VORSICHTSMASSNAHMEN UND EMPFEHLUNGEN. - BAND 2 BEHADELT BESONDERS DIE TECHNISCHE DATEN, DAS VERFAHREN ZUR MONTAGE DES BOOTES UND DER EINRICHTUNGEN.
----------------	--

INHALTSVERZEICHNIS

	Seite		Seite
⇒ Hauptphasen der Boots-inbetriebnahme	3	⇒ Druck	10
⇒ Kontrolle beim Auspacken	3	⇒ Montage der Ausstattung	11
⇒ Bootsmontage	4 - 6	⇒ Boot abpumpen / falten	12
⇒ Aufpumpsystem	7		
⇒ Boot Aufpumpen	8 - 9	⇒ Allgemeine Beschreibung	I - VI

HAUPTPHASEN DER BOOTSINBETRIEBNAHME

Wir empfehlen Ihnen, die genaue Reihenfolge des Montageverfahrens einzuhalten. Gehen Sie Schritt für Schritt vor und lesen Sie die jeweils angegebenen Verfahrenserklärungen auf den entsprechenden Seiten.

VERFAHREN	SEITE	ABSCHNITT
1. Prüfen Sie die Bestandteile Ihres Bootes auf Vollständigkeit und lernen Sie, wie Sie diese erkennen.	3	KONTROLLE BEIM AUSPACKEN
	I - VI	BESCHREIBUNG
2. Bringen Sie die Ventile in Aufpumpposition. Pumpen Sie den Tragschlauch leicht auf.	7	AUFPUMPSYSTEM
	8 - 9	BOOT AUFPUMPEN
3. CADET Solid oder CADET SP Alu : Bauen Sie den Bootsboden und die Holme zusammen. CADET Roll Up : Montieren Sie die Leisten. CADET AERO : Pumpen Sie den Fußboden auf.	5 - 6	BOOTSMONTAGE
	4	
	4	
4. Montieren Sie die Ruderbank.	11	MONTAGE DER AUSSTATTUNG
5. Beenden Sie das Aufpumpen des Bootes mit dem korrekten Betriebsdruck.	8 - 9	BOOT AUFPUMPEN
	10	DRUCK
6. Montieren Sie die Ruder.	11	MONTAGE DER AUSSTATTUNG

KONTROLLE BEIM AUSPACKEN

 ACHTUNG	VERWENDEN SIE KEIN SCHARFES WERKZEUG (CUTTER, MESSER USW.)
---	---

Die Verpackung Ihres Boots enthält 1 Tragschlauch +:

CADET	200-230-270 Roll Up	200-230 Aero	270-310 Aero	270-310-350 Alu
Leisten	X			
Fußboden aus Aluminium				X
Aufblasbarer Aero Fußboden		X	X	
Aufblasbarer Kiel			X	X
Holme			X	X
Standardausstattung				
Ruder	2	2	2	2
Fußpumpe	1	1	1	1
Abnehmbare Ruderbank	1	1	1	1
Transporttaschen	1	1	1	1
Reparaturkoffer	1	1	1	1
Eignerhandbuch	2	2	2	2

Sie können Ihr Boot mit optional erhältlichen Zubehörteilen ausstatten (Transporträder, Badeleiter, Hubringe usw.) Lassen Sie sich von Ihrem Fachhändler beraten.

HINWEIS	FALLS SIE HUBRINGE (ZUR DAVITAUFHÄNGUNG) ANBRINGEN MÖCHTEN, MÜSSEN SIE UNBEDINGT DIESE AUF DIE TRAGSCHLÄUCHE UND NICHT AUF DEN FUSSBODEN MONTIEREN (AUSSER BEIM 400SR – SIEHE «LAGE DER ZUBEHÖRTEILE»).
----------------	--

D
E
U
T
S
C
H

BOOTSMONTAGE



DIE MONTAGE AUF EINEM SAUBEREN UND GLATTEN FUSSBODEN VORNEHMEN.

WENN DAS BOOT BEI EINER TEMPERATUR VON UNTER 0° GELAGERT WIRD, LASSEN SIE ES VOR DEM AUSFALTEN FÜR 12 STUNDEN IN EINEM ORT BEI MILDER TEMPERATUR (20°C) RUHEN.

CADET ROLL UP – LEISTENFUSSBODEN:

Bei abgepumptem Boot schieben Sie die Leisten in ihre Taschen beginnend mit der Leiste, die sich am nächsten vom Spiegel befindet, ein. Falls sich eine Leiste schwer einschieben lässt, beschmieren Sie diese mit Flüssigseife.

CADET AERO: AUFBLASBARER AEROTEC FUSSBODEN

ABGEPUMPTER Hochdruckfußboden

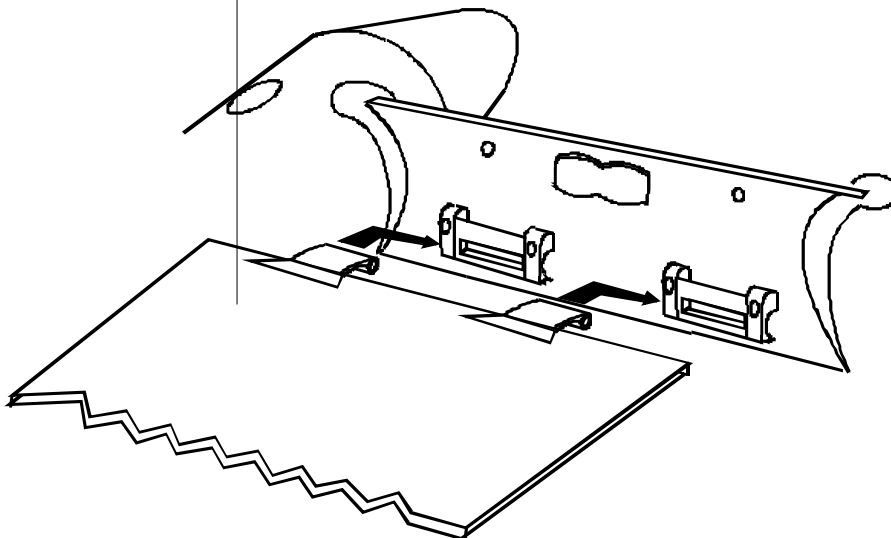

AUSBAU / PFLEGE DES AUFBLASBAREN HOCHDRUCKFUSSBODENS

Beim Falten empfehlen wir Ihnen, den Fußboden im Boot zu lassen.

Zur Reinigung des Bootsbodens, wo sich Sand und andere Rückstände ansammeln können, ist es jedoch hilfreich, den aufblasbaren Fußboden auszubauen. Hierzu verfahren Sie wie folgt:

- 1. AUSBAU:** Pumpen Sie den Tragschlauch und den Fußboden ab.
Schieben Sie den Fußbodenkeder aus seinen Klampen heraus (umgekehrtes Verfahren als bei der Montage).
- 2. PFLEGE:** Vor dem Ausspülen mit Wasserstrahl zwischen Tragschlauch und Bootsboden, pumpen Sie erneut das Boot ein wenig auf und heben Sie den Bug auf, um das Wasser zu evakuieren. Wiederholen Sie den Vorgang solange, bis der Sand oder die Rückstände komplett eliminiert sind.

BOOTSMONTAGE

CADET SOLID ODER CADET ALU - EINBAU DES FUSSBODENS AUS WASSERFEST VERLEIMTEM SPERRHOLZ ODER AUS ALUMINIUM.

- Um den Einbau der Fußbodenelemente zu erleichtern, streuen Sie Kartoffelmehl in die Schiene (verstärktes Band zwischen dem Tragschlauch und dem Bootsboden, siehe Abbildung 1.B).

ACHTUNG: VERWENDEN SIE NIEMALS TALKUM

- **Achten Sie auf die korrekte Richtung der Elemente:**
 - Der Fußboden besteht aus drei Elementen und zwei Bugplatten [Abb. 1].
 - Notieren Sie die Reihenfolge der Elemente.
 - Die Bugplatten haben eine Vorder- und eine Rückseite. Richten Sie sich nach den Rillen der Verbindungsprofile aus Aluminium; nach Einbau der Elemente müssen die Rillen sichtbar sein.Die Verstrebrungen müssen immer oben sein.

1. **Pumpen Sie** den Tragschlauch ein wenig auf (dadurch lassen sich die Fußbodenelemente leichter einsetzen).
2. **Setzen Sie** die Bugplatte (1) in die Schiene ein.
3. **Setzen Sie** das hintere Element (5) gegen den Spiegel (6) wie auf Abbildung 1 dargestellt.
4. **Stecken Sie** die Elemente ineinander [Abb.1].
5. **Formen Sie** die Fußbodenelemente (3) und (4) [Abb. 1 und 2] als "Dach"
6. **Prüfen Sie** die korrekte Ausrichtung der gesamten Einheit [Abb. 4].
7. Steigen Sie in das Boot und **treten Sie** das Dach platt, ziehen Sie dabei auf die Halteleinen, um ein Einquetschen des Gewebes zu vermeiden.
8. **Prüfen Sie**, dass der Fußboden korrekt in der Schiene liegt.
9. **Montieren Sie** die Holme wie nachstehend angegeben:

EINBAU DER HOLME

Die Holme dienen dazu, den Fußboden zu verriegeln und die Struktur zu versteifen, ein wesentlicher Punkt für die korrekte Seetauglichkeit des Boots.

1. Um den ersten Holm (7) leichter einsetzen zu können, schieben Sie den zweiten Holm um ca. 20 Zentimeter von der Kante unter den Bootsboden ein [Abb. 3].



SETZEN SIE NICHT DIE HOLME UNTER DEN BOOTSBODEN EIN ; BEVOR DER FUSSBODEN PLATT GETRETEN WURDE: SIE KÖNNTEN SONST DURCH DEN STOSS BESCHÄDIGT WERDEN.

2. **Legen Sie** die Holme entlang des Fußbodens; Die Markierung des Holmes (8) muss oben bleiben [Abb. 3].
3. **Prüfen Sie**, dass die Holme korrekt zwischen den Anschlägen (9) der Elemente 3 und 5 liegen [Abb. 4].
4. **Drehen Sie** die Holme um sich selbst, damit sie die Dicke des Fußbodens «sandwichartig» umschließen und sich korrekt in die Schienenmulde positionieren. **Die selbstspannende Struktur** des Fußbodens wird die Endplatzierung der Holme beim Aufpumpen des Tragschlauchs erleichtern.

BOOTSMONTAGE

Abb. 1-A



Abb. 1-B

a- Fußboden b- Tragschlauch
c- Schiene d- Bootsboden



Abb. 2

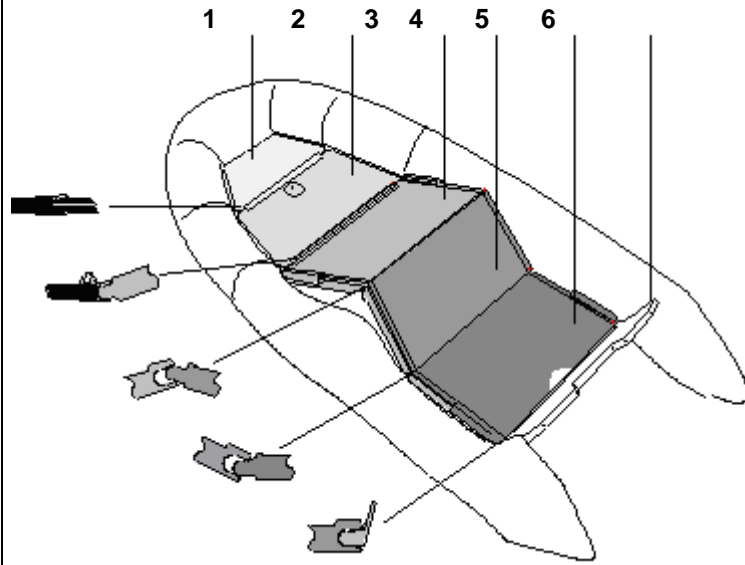

Abb. 3



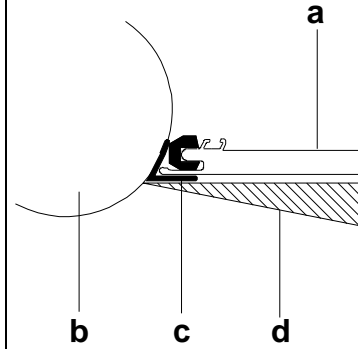



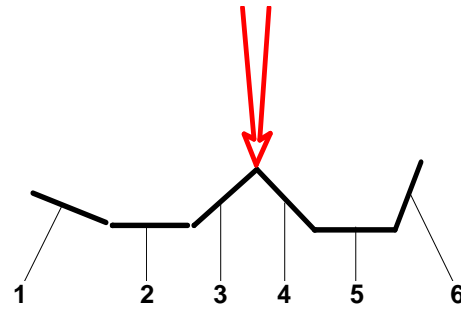
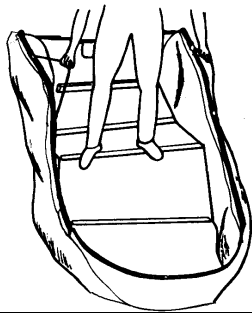

Abb. 4

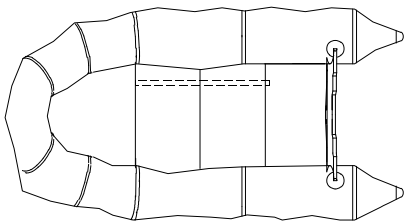
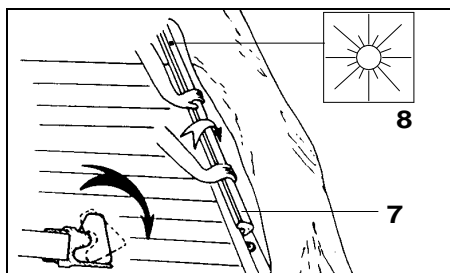
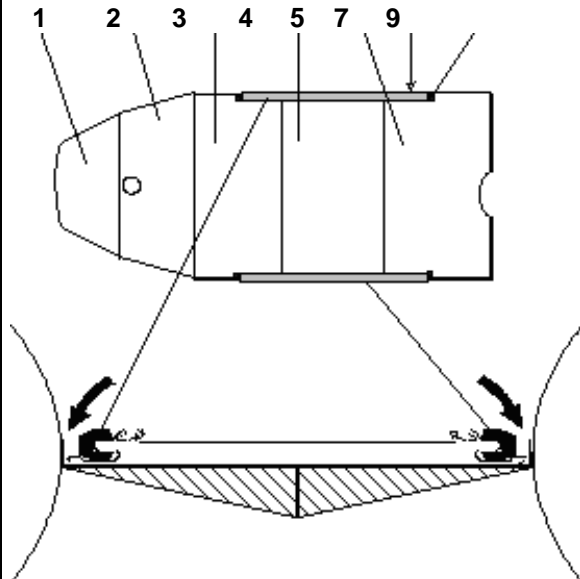

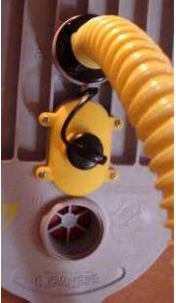
AUFPUMPSYSTEM

Bestandteile des Aufpumpsystems:

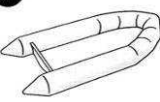
DER HOCHDRUCK BLASEBALG

<p>A</p>  <p>MAX </p> <p>MAX PRESSURE 0,3 bar (4,4 psi)</p> 	<p>B</p>  <p>MAX </p> <p>MAX PRESSURE 1,0 bar (14,7 psi)</p> 	<p>Position A (Stopfen hineingesteckt) Die Pumpe pumpt maximales Luftvolumen aber mit niedrigem Druck: diese Position verleiht allen aufblasbaren Teilen des Bootes schnell ihre Form.</p> <p>Position B (entfernen Sie den Stopfen) Das Pumpvolumen ist hier bei gleichem Krafteinsatz geringer als in Position A, liefert aber einen höheren Druck.</p>
<p>A</p> 	<p>A + B</p> 	<p>C</p> 

Position C
Zum entleeren. Stecken die Rohre ein, wie im Bild C aufgezeigt und pumpen Sie ganz normal.

STANDARDPUMPE

- A. Schlauchspitze
- B. Schlauchanschluss
- C. Aufpumpöffnung

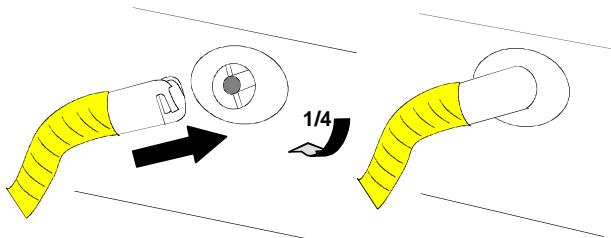
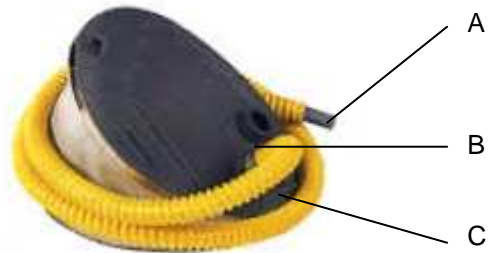

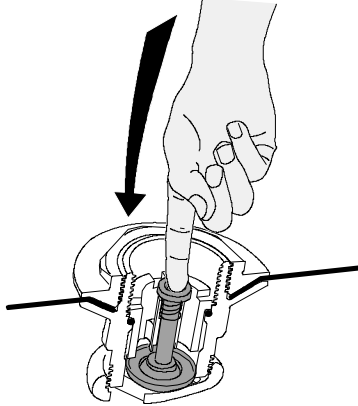
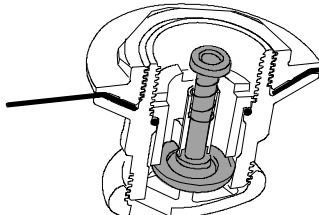
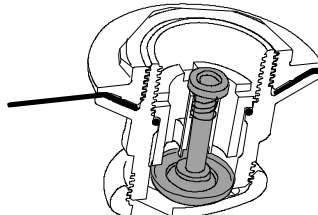

VENTILE	Position AUFBLASEN	Position ENTLÜFTEN
<p>Umschalten der versenkten Ventile</p> 		
Drücken	Membrane geschlossen, Drehknopf springt nach oben	Membrane geöffnet, Drehknopf geht abwärts

AUFPUMPEN EIN NICHT AERO BOOT

Alle Ventile in Aufpumpposition aktivieren.

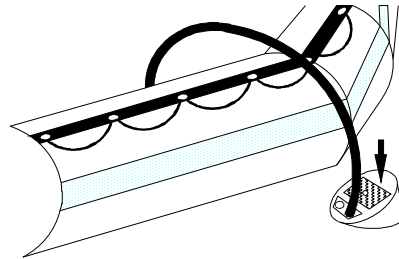
Befestigen Sie den Schlauchanschluss auf den Aufpumpstutzen der Fußpumpe.
Um Ihr Boot korrekt aufzupumpen, muss die Fußpumpe stabil auf dem Boden liegen.
Das Boot wird schneller aufgepumpt, wenn die Fußpumpe mit mäßigem Druck und ohne Hast betätigt wird.







 ACHTUNG	VERWENDEN SIE KEINEN KOMPRESSOR BZW. KEINE DRUCKLUFTFLASCHE.
---	---

Sie können die ACCESS Elektropumpe, die bei Ihrem Händler erhältlich ist, verwenden.

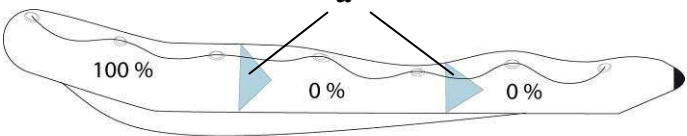
TRAGSCHLAUCH AUFPUMPEN

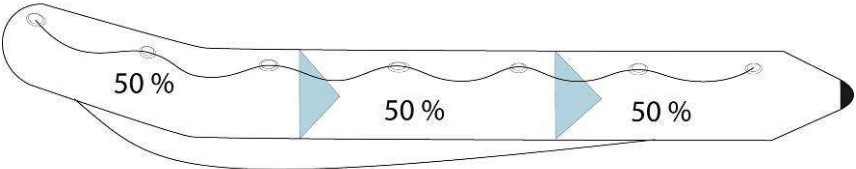
- Pumpen Sie den Tragschlauch auf mit **gleichmäßigem Druck zwischen den verschiedenen Kammern, bis die Kammerzwischenwände (a) nicht mehr zu sehen sind (Druck = siehe Abschnitt DRUCK)**

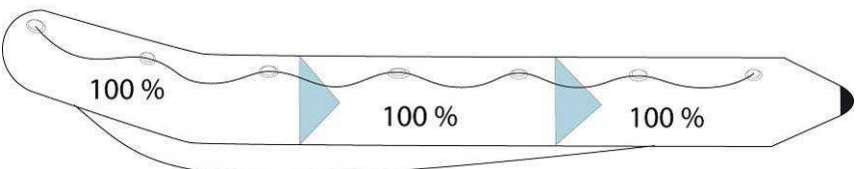
	Pumpen Sie niemals eine Kammer voll auf, wenn die anderen völlig leer sind	
	1	
	2	

AUFPUMPEN DES KIELS

- **Nach Montage des Fußbodens** beginnen Sie mit dem Aufpumpen (**siehe Abschnitt DRUCK**).

Der Pumpvorgang ist abgeschlossen: Schrauben Sie die Ventilverschlüsse auf.

HINWEIS	Vor Aufschrauben der Ventilschlüsse ist ein leichter Luftverlust normal. DIE EIGENTLICHE DICHTHEIT WIRD AUSSCHLIESSLICH DURCH DIE VERSCHLÜSSE GEWÄHRLEISTET.
----------------	--

AUFPUMPEN EIN AERO BOOT

Aktivieren aller Ventile in Aufpumpposition.

Befestigen Sie den Schlauchanschluss auf den Aufpumpstutzen der Fußpumpe.

Um Ihr Boot korrekt aufzupumpen, muss die Fußpumpe stabil auf dem Boden liegen.

Das Boot wird schneller aufgepumpt, wenn die Fußpumpe mit mäßigem Druck und ohne Hast betätigt wird.

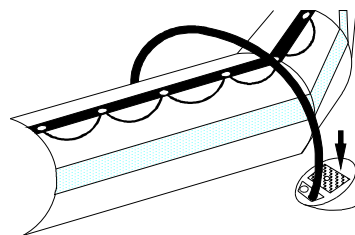

 ACHTUNG	VERWENDEN SIE KEINEN KOMPRESSOR BZW. KEINE DRUCKLUFTFLASCHE.
--------------------	---

A – AUFPUMPEN DES HOCHDRUCK-FUSSBODENS (NUR FÜR AEROTEC MODELLE)

1. **Aufpumpen:** Schieben Sie den Schlauch wie auf Abbildung A dargestellt ein und beginnen Sie das Aufpumpen **mit eingesetztem Stopfen**. Die Pumpe liefert ihre volle Leistung. Pumpen Sie, bis die Pumpe sich hart anfühlt.
2. **Entfernen Sie anschließend den Stopfen.** Die Pumpe benutzt automatisch eine kleinere Kammer, so dass der Aufpumpdruck des Hochdruckfußbodens mühelos erreicht werden kann. **Pumpen Sie** weiter in Stellung B bis zur Erreichung des empfohlenen Druckwertes (**siehe Abschnitt DRUCK**).

B - AUFPUMPEN DES HAUPTTRAGSCHLAUCHES UND DES KIELS

 ACHTUNG	VERWENDEN SIE NIEMALS DIE STELLUNG B ZUM AUFPUMPEN DES HAUPTTRAGSCHLAUCHES BZW. DES KIELS: SIE RISKIEREN SONST, DASS DIESE PLATZEN.
--------------------	--

Tragschlauch aufpumpen: Schieben Sie den Schlauch wie auf Abbildung A dargestellt ein und beginnen Sie das Aufpumpen mit eingesetztem Stopfen. Die Pumpe liefert ihre volle Leistung, so dass der empfohlene Druck (**siehe Abschnitt DRUCK**) erreicht werden kann. **Pumpen Sie mit gleichmäßigem Druck zwischen den verschiedenen Kammern**, bis die Kammerzwischenwände (a) nicht mehr zu sehen sind.

	Pumpen Sie niemals eine Kammer voll auf, wenn die anderen völlig leer sind	
	1	
	2	

Der Pumpvorgang ist abgeschlossen: Schrauben Sie die Ventilverschlüsse auf.

HINWEIS	Vor Aufschrauben des Ventilverschlusses ist ein leichter Luftverlust normal. DIE EIGENTLICHE DICHTHEIT WIRD AUSSCHLIESSLICH DURCH DIE VERSCHLÜSSE GEWÄHRLEISTET.
----------------	--

DEUTSCH

DRUCK

Der Betriebsdruck für den Tragschlauch beträgt 240 mb (3,48 PSI); für den aufblasbaren Aerotec Fußboden beträgt der Betriebsdruck 600 mb (8.5 PSI).

Falls Ihr Boot nicht mit einem **ACCESS** Manometer ausgestattet ist, empfehlen wir Ihnen, dieses bei Ihrem Händler zu erwerben. Damit ist eine schnelle und wirksame Druckkontrolle beim Aufpumpen möglich. Ohne Manometer beenden Sie das Aufpumpen, sobald der Tragschlauch genügend fest ist und sich die Kegeln am Ende des Tragschlauches nicht mehr per Hand biegen lassen.

Die Temperatur der Umgebungsluft bzw. des Wassers übt einen proportionalen Einfluss auf die Druckhöhe innerhalb des Tragschlauches aus:

Umgebungstemperatur	Tragschlauchinnendruck
+1 °C	+4 mb / 0,06 PSI
-1 °C	-4 mb / 0,06 PSI

Daher ist es wichtig vorzusehen:

Prüfen Sie den Druck der Luftkammern und passen Sie ihn (durch Nachpumpen bzw. Entleeren) entsprechend den Temperaturschwankungen an (vor allem bei großen Temperaturschwankungen zwischen Morgen- und Abendstunden in besonders warmen Zonen), prüfen Sie auch, dass der Druck innerhalb des empfohlenen Bereichs bleibt (zwischen 220 und 270 mb / grüner Bereich).

UNTERDRUCKGEFAHR

BEISPIEL: Ihr mit empfohlenem Druck (240 mb/3,48 PSI) aufgepumptes Boot lagert auf dem Strand unter praller Sonne (Temperatur = 50 °C). Wenn Sie es ins Wasser (Temperatur = 20 °C) schieben, werden Temperatur und Druck innerhalb der Luftkammern gemeinsam sinken (bis 120 mb) und **SIE WERDEN NACHPUMPEN MÜSSEN**, bis die wegen des Unterschieds zwischen Luft- und Wassertemperatur verlorenen Millibars ausgeglichen werden. Das Feststellen einer Druckverminderung bei sinkender Außentemperatur am Ende des Tages ist daher völlig normal.

HINWEIS

Falls es zu wenig aufgepumpt ist, besitzt Ihr Boot nicht ausreichend Rigidität beim Navigieren, es liefert eine schlechte Leistung und kann vorzeitig altern.

ÜBERDRUCKGEFAHR

BEISPIEL: Ihr Boot ist am Anfang bzw. Ende des Tages (niedrige Außentemperatur = 10 °C) mit dem empfohlenen Druck (240 mb/3,48 PSI) aufgepumpt. Später am Tag liegt Ihr Boot auf dem Strand oder dem Deck einer Yacht unter praller Sonne (Temperatur = 50 °C). Die Temperatur innerhalb der Luftkammern kann dann steigen und bis 70 °C erreichen (besonders bei einem Tragschlauch von dunkler Farbe), so dass der Anfangsdruck verdoppelt wird (480 mb). **SIE MÜSSEN ALSO LUFT ABLASSEN**, um den empfohlenen Druck erneut zu erreichen.



ACHTUNG

FALLS IHR BOOT ÜBERMÄSSIG AUFGEPUMPT IST, WIRD DIE AUFBLASBARE STRUKTUR DURCH DEN DRUCK UNNORMAL BEANSPRUCHT UND EIN BRUCH DER VERBUNDENEN ELEMENTE KANN DARAUSS ENTSTEHEN.

IM FALLE EINES ÜBERDRUCKS

Entlüften Sie durch vorsichtiges Drücken auf den federbelasteten Drehknopf

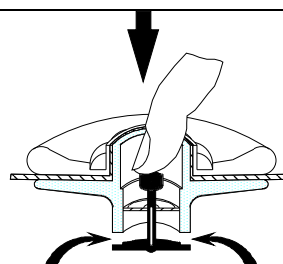

MONTAGE DER AUSSTATTUNG

DIE RUDER

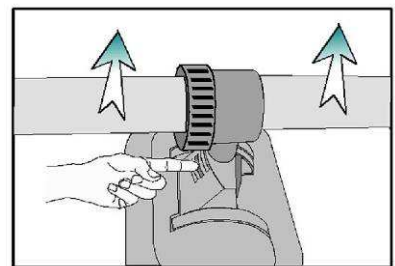
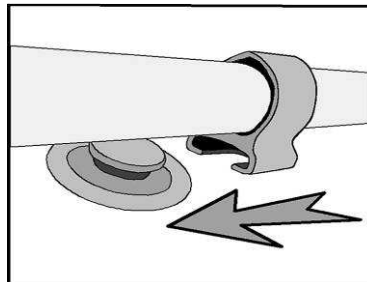
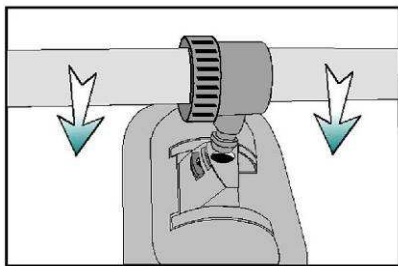
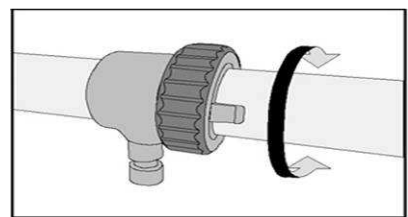
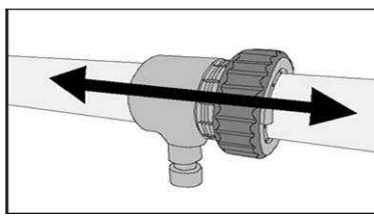
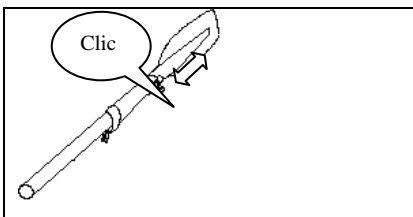
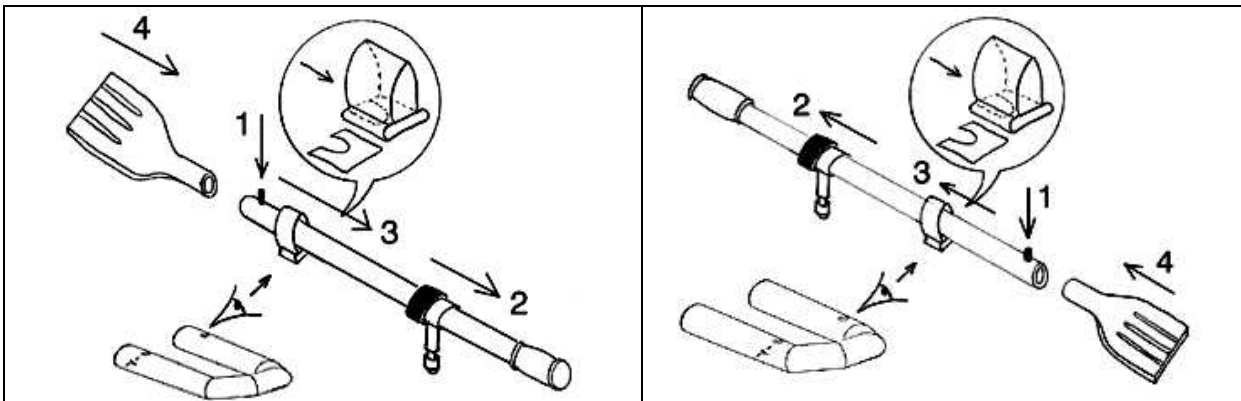

DEUTSCH

DIE RUDERBANK

Montieren Sie die Ruderbank vor dem Aufpumpen.

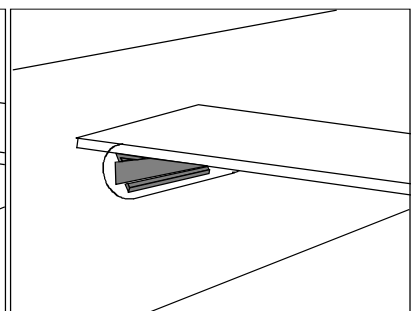
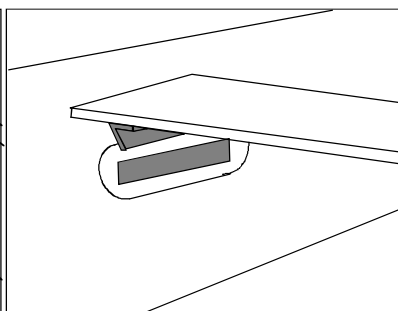
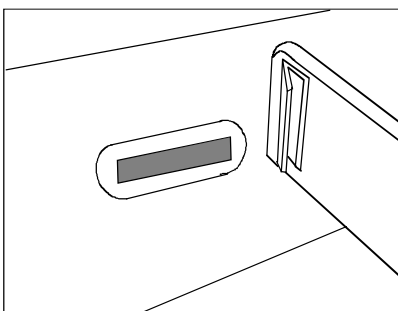

BOOT ABPUMPEN / FALTEN

1. **Pumpen Sie** das Boot ab und bringen Sie zur Lagerung die Ventilschutzverpackungen wieder an.
2. **Entfernen Sie** die Ruder (umgekehrtes Verfahren als bei der Montage) und die etwaigen Sonderausstattungen.
3. **Bauen Sie** den Fußboden ab (S Modelle) in umgekehrter Reihenfolge als bei der Montage. Bei den Booten mit Leisten brauchen diese beim Falten nicht herausgenommen zu werden.
4. **Nehmen Sie** die Stöpsel der Lenzschnellventile ab und **entleeren Sie** eventuell eingedrungenes Wasser aus dem Boot (im Falle einer langfristigen Lagerung prüfen Sie vor dem Falten, dass das Boot richtig trocken ist).
5. **Falten Sie** die 2 Tragschlauchhälften zur Bootsinnenseite zurück (A), biegen Sie die Koneen gegen den Spiegel (B) und wickeln Sie das Boot um den Spiegel (C). Falls Sie feststellen, dass Luft in den Tragschläuchen noch vorhanden ist, wiederholen Sie den Vorgang.

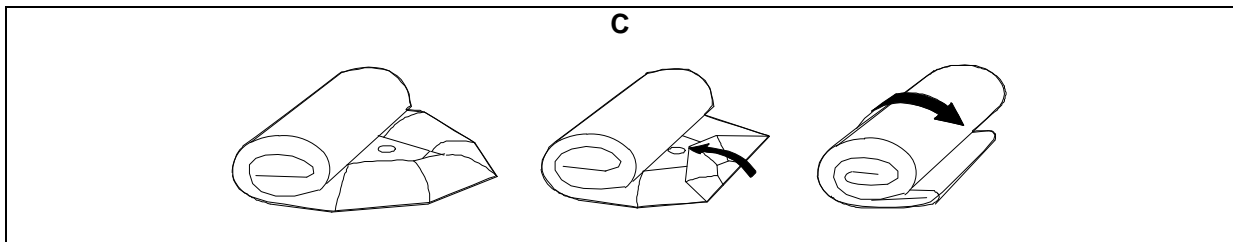
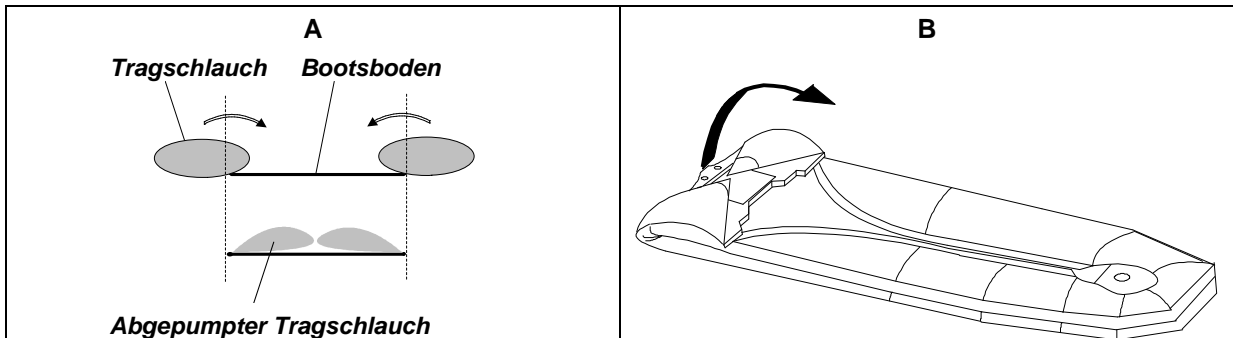

6. **Verstauen Sie** das Boot in seine Packtaschen.



CADET

200 Roll Up - 230 Roll Up - 270 Roll Up

200 Aero - 230 Aero - 270 Aero - 310 Aero - 350 Aero

270 ALU - 310 ALU - 350 ALU

Tomo 2

TOMO 2

CARACTERÍSTICAS TÉCNICAS - PROCEDIMIENTO DE MONTAJE



 ADVERTENCIA	<ul style="list-style-type: none"> ● LEA ATENTAMENTE ESTE MANUAL ANTES DE PONER EN SERVICIO LA EMBARCACIÓN. ● EL MANUAL DEL PROPIETARIO CONSTA DE DOS TOMOS QUE SE DEBE CONSERVAR JUNTOS.
---	---

NOTA:	<p>EL MANUAL DEL PROPIETARIO CONSTA DE DOS TOMOS:</p> <p>- TOMO 1 TRATA DE UNA MANERA GENERAL DE LAS PRECAUCIONES USUALES Y DE LAS RECOMENDACIONES CON QUE SE DEBE CUMPLIR A BORDO DE LA EMBARCACIÓN Y EN EL AGUA.</p> <p>- TOMO 2 TRATA MÁS EN PARTICULAR DE LAS CARACTERÍSTICAS TÉCNICAS Y DEL MONTAJE DE LA EMBARCACIÓN Y DE SU EQUIPO.</p>
--------------	---

ÍNDICE GENERAL

	Página		Página
⇒Las principales etapas de la puesta en servicio de la embarcación	3	⇒Presión	10
⇒Inventario al abrir el embalaje	3	⇒Montaje del equipo	11
⇒Montaje de la embarcación	4 - 6	⇒Desinflado / plegado de la embarcación	12
⇒El sistema de inflado	7		
⇒Inflado de la embarcación	8 - 9	⇒Descripción general	I - VI

LAS PRINCIPALES ETAPAS DE LA PUESTA EN SERVICIO DE LA EMBARCACIÓN

El procedimiento de montaje de la embarcación sigue un orden que le pedimos respetar. Proceda etapa por etapa consultando cada vez las páginas indicadas para las explicaciones de procedimiento.

PROCEDIMIENTO	PÁGINA	SECCIÓN
1. Haga el inventario de los elementos que constituyen su embarcación y aprenda a reconocerlos.	3	INVENTARIO EN EL MOMENTO DE LA APERTURA
	I - VI	DESCRIPCIÓN
2. Active las válvulas en posición de inflado. E infle ligeramente el flotador.	7	SISTEMA DE INFLADO
	8 - 9	INFLADO DE LA EMBARCACIÓN
3. CADET Alu: Monte el piso y los largueros CADET Roll Up: Monte los listones. CADET Aero: Infle el piso.	5 - 6	MONTAJE DE LA EMBARCACIÓN
	4	
	4	
4. Instale la bancada.	11	MONTAJE DE LOS EQUIPOS
5. Termine el inflado de la embarcación a las presiones de utilización.	8 - 9	INFLADO DE LA EMBARCACIÓN
	10	PRESIÓN
6. Coloque los remos.	11	MONTAJE DE LOS EQUIPOS

INVENTARIO AL ABRIR EL EMBALAJE

 ATENCIÓN	NO UTILIZAR HERRAMIENTAS CON FILO (CUTTER, CUCHILLO, ETC.)
--	---

El embalaje de su embarcación contiene 1 flotador +:

CADETCADDET	200-230-270 Roll Up	200-230 Aero	270-310 Aero	270-310-350 Alu
Listones	X			
Piso aluminio				X
Piso inflable AEROTEC		X	X	
Quilla inflable			X	X
Largueros			X	X
Equipos estándar				
Remos	2	2	2	2
Inflador	1	1	1	1
Bancada amovible	1	1	1	1
Bolsa de transporte	1	1	1	1
Maletín de reparación	1	1	1	1
Manual del propietario	2	2	2	2

Usted puede equipar su embarcación con accesorios opcionales (ruedas de transporte, escala de baño, anillos de levantamiento, etc.). Solicite asesoramiento a su agente.

NOTA:	SI DESEA AÑADIR ANILLOS DE LEVANTAMIENTO (PARA LA PUESTA BAJO PESCANES), DEBE FIJARLOS IMPERATIVAMENTE EN LOS FLOTADORES Y NO EN EL PISO (SALVO PARA LA 400SR, VER «EMPLAZAMIENTO DE LOS ACCESORIOS»).
--------------	---

MONTAJE DE LA EMBARCACIÓN



PROCEDA AL MONTAJE SOBRE UN SUELO LIMPIO Y LISO.
SI SE ALMACENA LA EMBARCACIÓN A UNA TEMPERATURA INFERIOR A 0°C,
DÉJELA 12 HORAS EN UN LUGAR TEMPLADO (20°C) ANTES DE
DESPLGARLA.

CADET ROLL UP – PISO DE LISTONES

Con la embarcación desinflada, introduzca los listones en sus cartelas comenzando por el listón más cercano al tablero. Si resulta difícil insertar un listón, lubríquelo con jabón líquido.

CADET AERO - PISO INFLABLE AEROTEC

Piso de alta presión DESINFLADO

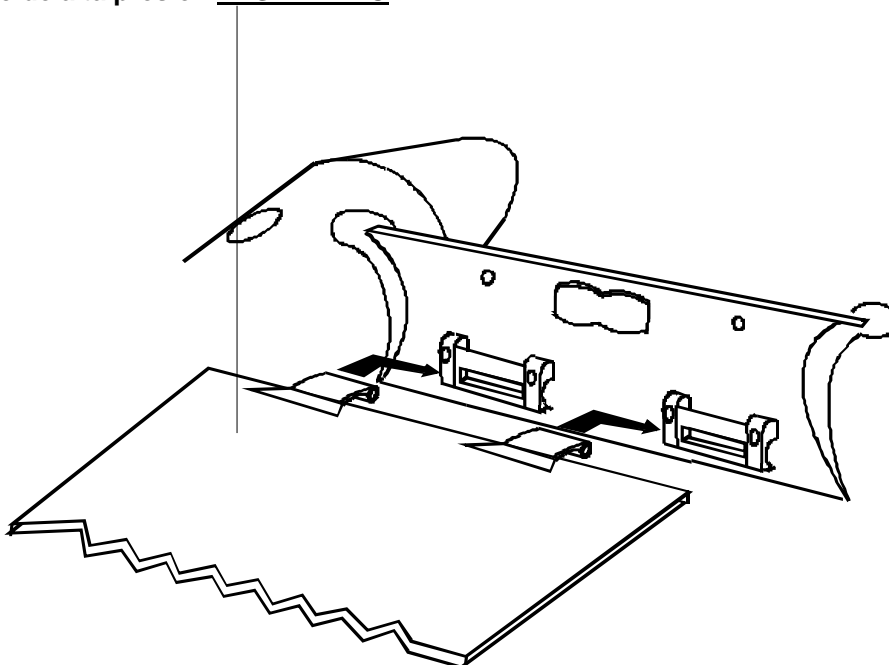

DESMONTAJE / MANTENIMIENTO DEL PISO INFLABLE DE ALTA PRESIÓN

Al realizar al plegado, le aconsejamos dejar el piso colocado en la embarcación. Sin embargo, para limpiar el fondo de la embarcación donde se pueden acumular la arena y otros residuos, puede resultar útil retirar el piso inflable. Proceda entonces de la siguiente manera:

- 1. DESMONTAJE:** Desinfe el flotador y el piso.
Haga deslizar la relinga del piso fuera de sus galápagos (procedimiento inverso a aquel del montaje).
- 2. MANTENIMIENTO:** Vuelva a inflar ligeramente la embarcación antes de enjuagar con un chorro entre el flotador y el fondo, y luego levante la punta de la embarcación para evacuar el agua. Repita la operación hasta haber evacuado toda la arena o los residuos.

MONTAJE DE LA EMBARCACIÓN

CADET SOLID O SP ALU - COLOCACIÓN DEL PISO CONTRACHAPADO MARINO O ALUMINIO

- Ponga fécula de patata en el angular (cinta reforzada situada entre el flotador y el fondo, ver la figura 1.B) para facilitar la colocación de los elementos de piso.

ATENCIÓN: NUNCA TALCO.

- **Identifique bien los elementos y su sentido:**
 - El piso está compuesto de tres elementos de piso y dos paneles delanteros [fig 1].
 - Identifique el orden de los elementos.
 - Los paneles tienen un lado derecho y un lado revés. Oriéntese con las rayas de los perfiles de aluminio de unión; éstas deben ser visible una vez montados los elementos. Los refuerzos siempre deben estar encima.

1. **Infle** ligeramente el flotador (esto facilitará la colocación de los elementos de piso).
2. **Introduzca** el panel delantero (1) en el angular.
3. **Introduzca** el elemento trasero (5) contra el tablero (6) como está indicado en la figura 1.
4. **Encaje** los elementos unos en otros [fig.1].
5. **Ponga en "techo"** los elementos de piso (3) y (4) [fig 1 y 2].
6. **Verifique** que el conjunto está bien alineado [fig 4].
7. **Aplane** el techo subiendo al bote y tirando de las asas hacia arriba para evitar atascar la tela [fig. 2].
8. **Verifique** que el piso está bien colocado en el angular.
9. **Instale** los largueros como está indicado más abajo:

COLOCACIÓN DE LOS LARGUEROS

Los largueros permiten bloquear el piso y rigidizar su estructura, elemento esencial para la buena navegabilidad de la embarcación.

1. Para facilitar la colocación del primer larguero (7), deslice el segundo larguero debajo del fondo de la embarcación a 20 centímetros aproximadamente del bordo [fig. 3].



NO COLOQUE EL LARGUERO DEBAJO DEL FONDO DE LA EMBARCACIÓN ANTES DE HABER APLANADO EL PISO: EL CHOQUE PODRÍA DAÑARLOS.

2. **Coloque** los largueros a lo largo del piso; la marca del larguero (8) debe permanecer encima [fig. 3].
3. **Cerciórese** de que los largueros están colocados correctamente entre los topes (9) de los elementos 3 y 5 [fig. 4].
4. **Haga girar** los largueros sobre sí mismos de modo que tomen en «sándwich» el espesor del piso y se ubiquen correctamente en la cavidad del angular [fig. 3 y 4].
5. **La estructura** de auto apriete del piso facilitará la colocación final de los largueros durante el inflado del flotador.

MONTAJE DE LA EMBARCACIÓN

fig 1-A

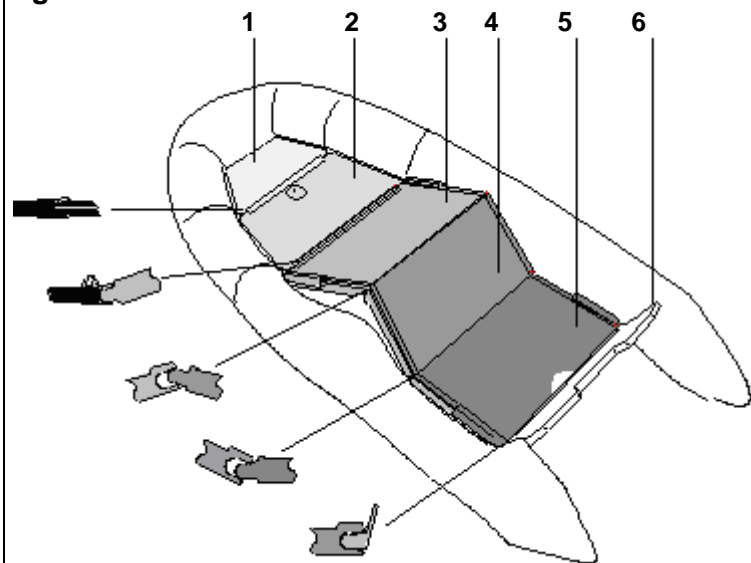

fig 1-B

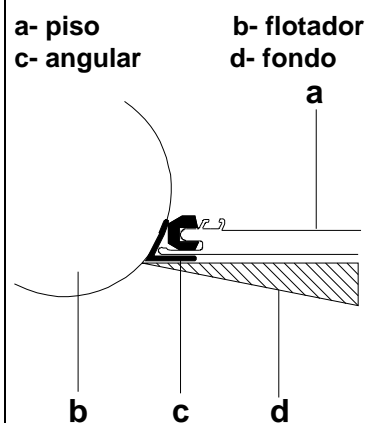

fig 2

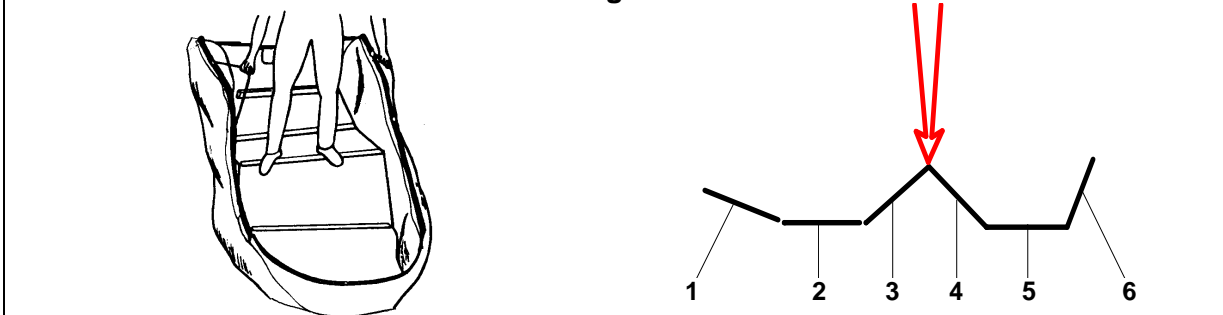

fig 3

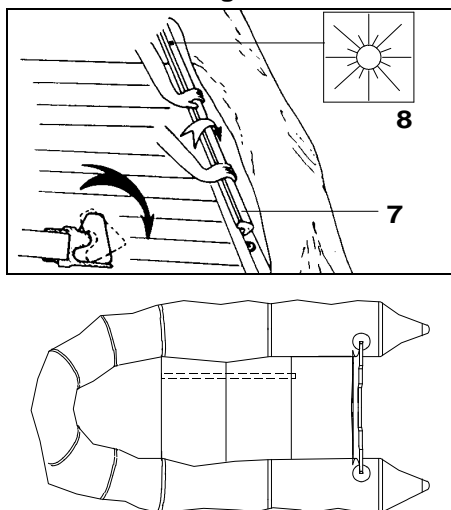
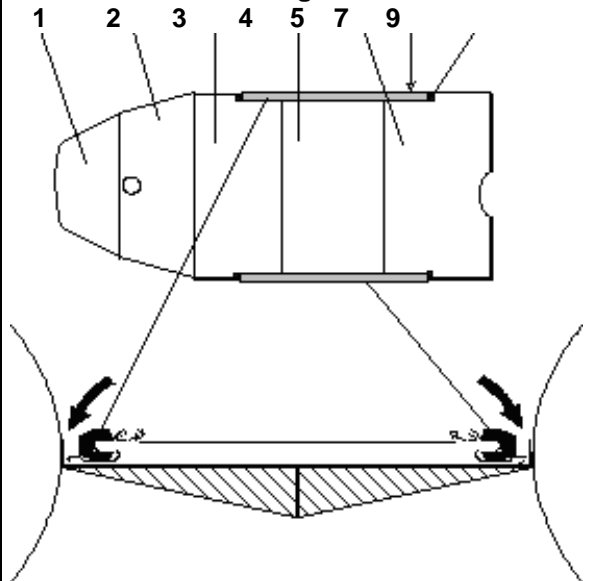

fig 4



SISTEMA DE INFLADO

El sistema de inflado consta de:

EL HINCHADOR DE ALTA PRESIÓN

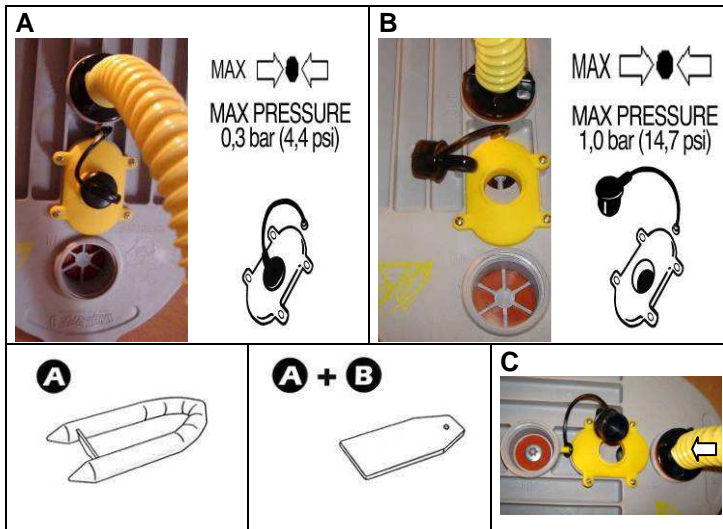

En posición A: (con el tapon)

El hinchador tiene un caudal máximo pero una presión débil: posición para poner rápidamente en forma todos los elementos hinchables.

En posición B (quitar el tapon)

El hinchador tiene un caudal inferior a la posición A, pero permite alcanzar con el mismo esfuerzo una presión superior.

En posición C :

Para desinflar, introducir el tubo como indicado en la fig. C y bombear normalmente

EL INFLADOR ESTÁNDAR

- A. extremo del tubo
- B. base del tubo
- C. orificio de inflado

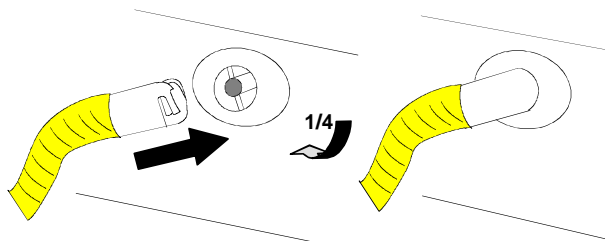
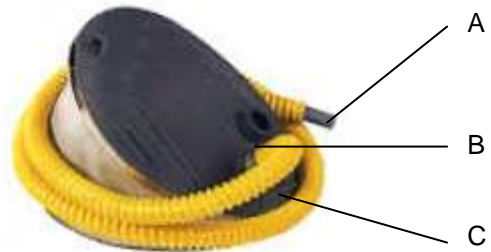

LAS VÁLVULAS

	posición de hinchado	posición de deshinchado
Apriete	La membrana está cerrada, el pulsador en posición alta	La membrana está abierta, el pulsador en posición baja

INFLADO DE UNA EMBARCACIÓN NO AEROTEC

Active todas las válvulas a la posición de inflado.

Fije la base del tubo en el orificio de inflado del inflador.

Para inflar correctamente su embarcación, es necesario que el inflador tenga un buen apoyo en el suelo.

La embarcación se infla rápidamente si el inflador es accionado con soltura y sin precipitación.

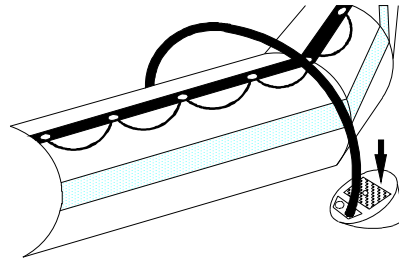





 ATENCIÓN	NO UTILIZAR UN COMPRESOR O UNA BOTELLA DE AIRE COMPRIMIDO.
--	---

Puede utilizar el inflador eléctrico *ACCESS* en venta donde su agente.

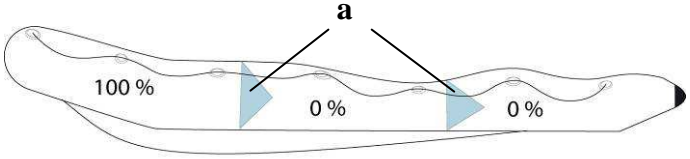
INFLADO DEL FLOTADOR

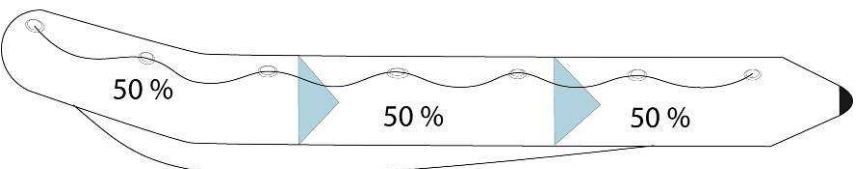
- Proceda al inflado del flotador **equilibrando las presiones entre los diferentes compartimentos, hasta que los mamparas (a) ya no sean visibles (presión = ver la sección PRESIÓN).**

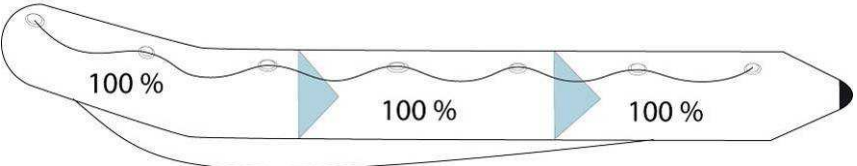
	Nunca poner bajo presión un compartimento con los otros completamente desinflados.	
	1	
	2	

INFLADO DE LA QUILLA

- **Una vez montado el piso,** proceda al inflado (**ver la sección PRESIÓN**).

El inflado ha terminado: Enrosque los tapones de las válvulas de inflado.

NOTA:	Es normal observar una ligera fuga de aire antes de enroscar el tapón de válvula. SOLO LOS TAPONES ASEGURAN LA ESTANQUEIDAD FINAL.
--------------	--

INFLADO DE UNA EMBARCACIÓN CADET AERO

Active todas las válvulas a la posición de inflado.

Fije la base del tubo en el orificio de inflado del inflador.
 Para inflar correctamente su embarcación, es necesario que el inflador tenga un buen apoyo en el suelo.
 La embarcación se infla rápidamente si el inflador es accionado con soltura y sin precipitación.

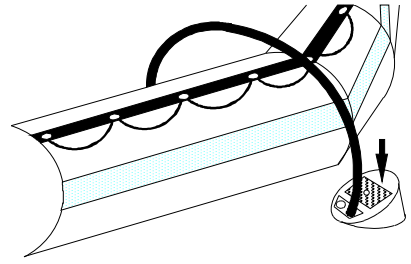

 ATENCIÓN	NO UTILIZAR UN COMPRESOR O UNA BOTELLA DE AIRE COMPRIMIDO.
--	---





A - INFLE EL PISO DE ALTA PRESIÓN (MODELOS AEROTEC ÚNICAMENTE).

1. **Infle** Inserte el tubo como está indicado en la figura A y empiece a inflar dejando **el tapón insertado**. El inflado aprovecha completamente su capacidad. Infle hasta que el manejo se vuelva duro.
2. Luego **retire el tapón**. La bomba utiliza automáticamente una cámara más pequeña que permite alcanzar sin esfuerzo la presión de inflado del fondo de Alta presión. **Termine** el inflado en la posición **B** hasta alcanzar la presión recomendada (**ver la sección PRESIÓN**).

B - INFLE EL FLOTADOR PRINCIPAL Y LUEGO LA QUILLA

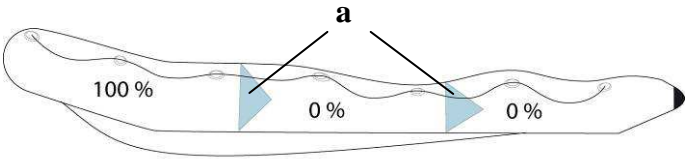
 ATENCIÓN	NUNCA UTILICE LA POSICIÓN B PARA INFLAR EL FLOTADOR O LA QUILLA. HABRÍA PELIGRO DE EXPLOSIÓN.
--	--

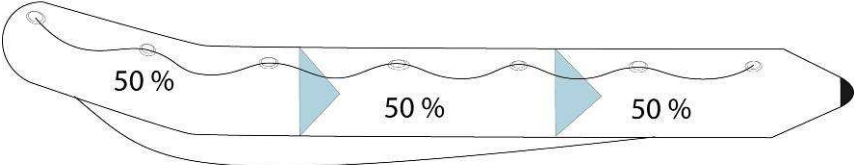
Infle el flotador Inserte el tubo como está indicado en la figura A y empiece a inflar dejando **el tapón insertado**. El flotador aprovecha completamente su capacidad y permite alcanzar la presión recomendada (**ver la sección PRESIÓN**). **Procure equilibrar las presiones entre los diferentes compartimentos**, hasta que los mamparas (a) ya no sean visibles.

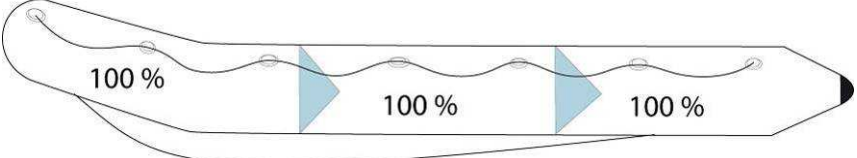
	Nunca poner bajo presión un compartimento con los otros completamente desinflados.	
	1	
	2	

El inflado ha terminado: Enrosque los tapones de las válvulas de inflado.

NOTA:	Es normal observar una ligera fuga de aire antes de enroskar el tapón. SOLO LOS TAPONES ASEGURAN LA ESTANQUEIDAD FINAL.
--------------	---

E
S
P
A
Ñ
O
L

PRESIÓN

La presión de utilización para el flotador y la quilla es de 240 mb (3,48 PSI); la presión de utilización del fondo inflable Aerotec es de 600 mb (8.5 PSI).

Si su embarcación no está equipada con un indicador de presión **ACCESS**, le recomendamos obtener uno donde su agente. Éste le permitirá una lectura rápida y eficaz durante el inflado. Sin indicador de presión, deje de inflar en cuanto el flotador esté lo suficientemente firme como para que ya no se pueda acodar a mano los conos en la parte trasera del flotador.

La temperatura ambiente del aire o del agua influye proporcionalmente en el nivel de la presión interna del flotador:	Temperatura ambiente	Presión interna del flotador
	+1°C	+4 mb / 0,06 P SI
	-1°C	-4 m b / 0,06 PSI

Por esto, es importante saber anticipar :

Verifique y ajuste la presión de los compartimientos inflables (volviendo a inflar o desinflando según el caso) en función de las variaciones de temperatura (sobre todo cuando las diferencias de temperatura son importantes entre la mañana y la noche en las zonas particularmente calientes) y asegúrese de que la presión no se aleje de la zona de presión recomendada (de 220 a 270 mb / zona verde).

RIESGO DE SUBPRESIÓN

EJEMPLO: Su embarcación está expuesta en la playa a plena luz del sol (temperatura =50 °C) a la presión recomendada (240 mb/3,48 PSI). Cuando lo mete al agua (temperatura=20°C), la temperatura y la presión interna de los compartimientos inflables bajarán conjuntamente (hasta 120 mb) y **USTED TENDRÁ ENTONCES QUE VOLVER A INFLAR** hasta recuperar los milibares perdidos por la diferencia de temperatura entre el aire ambiente y el agua. Por esto, es normal observar una disminución de presión al final del día cuando baja la temperatura exterior.

NOTA:

Subinflada, a su embarcación le falta rigidez durante la navegación, ofrece malas prestaciones y corre peligro de envejecer prematuramente.

RIESGO DE SOBREPRESIÓN

EJEMPLO: Su embarcación está inflada a su presión recomendada (240 mb /3,48 PSI) al comienzo o al final del día (temperatura exterior baja =10°C). Más tarde durante el día, su embarcación está expuesta a plena luz del sol en la playa o en la cubierta de un yate (temperatura=50°C). La temperatura interior de los compartimientos inflables puede entonces subir y llegar a 70°C (flotadores de color oscuro sobre todo) ocasionando una duplicación de la presión inicial (480 mb). **USTED TENDRÁ ENTONCES QUE DESINFLAR** para regresar a la presión recomendada.



SI SU EMBARCACIÓN ESTÁ DEMASIADO INFLADA, LA PRESIÓN SOLICITA DE MANERA ANORMAL LA ESTRUCTURA INFLABLE, LO QUE PUEDE OCASIONAR UNA ROTURA DE MONTAJE.

EN CASO DE SOBREPRESIÓN

Deje escapar el aire apoyando sobre el pulsador de la válvula.

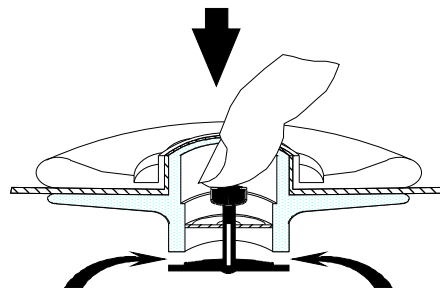

MONTAJE DEL EQUIPO

LOS REMOS

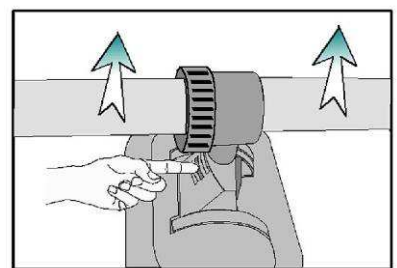
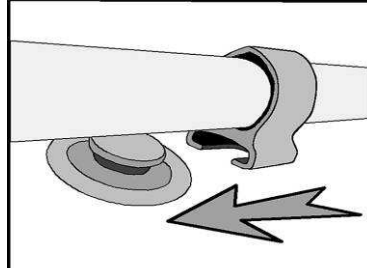
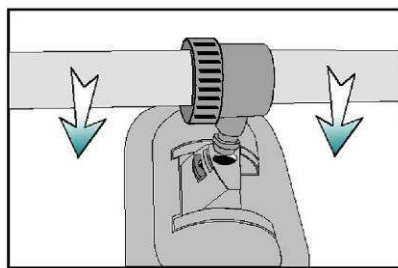
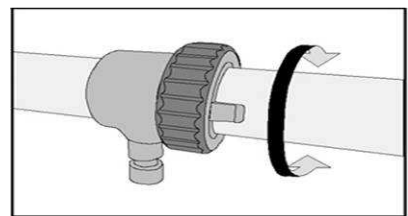
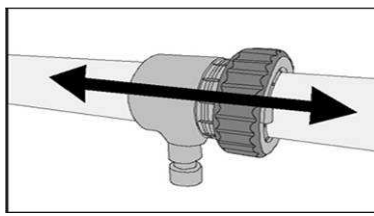
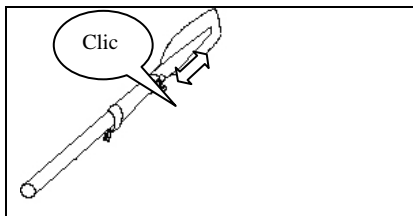
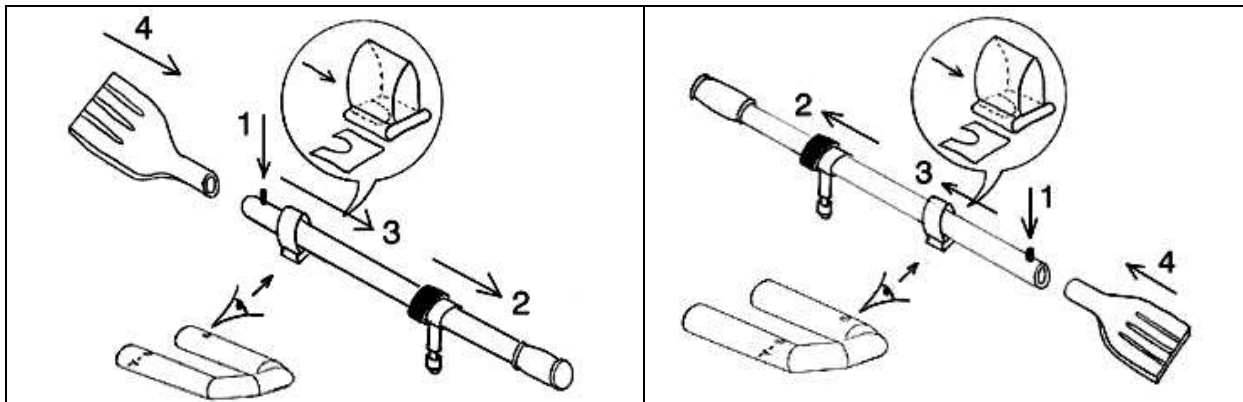

LA BANCADA

Instale la bancada antes de terminar el inflado.

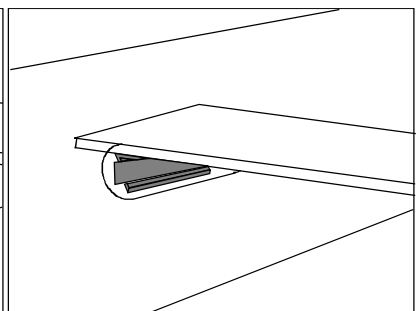
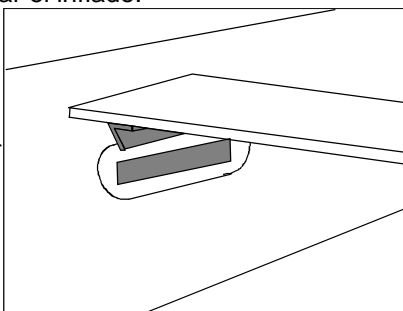
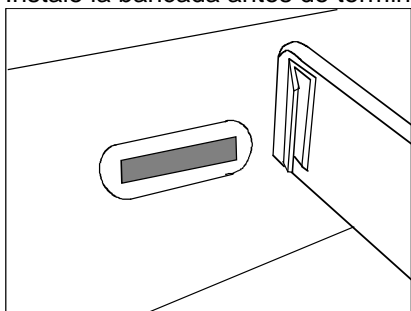

DESINFLADO / PLEGADO DE LA EMBARCACIÓN

1. **Desinifle** la embarcación y vuelva a poner las protecciones de las válvulas para el almacenamiento.
2. **Retire** los remos (según el procedimiento inverso al del montaje) y los posibles equipos opcionales.
3. **Retire** el piso (S embarcaciones) según el procedimiento inverso al del montaje. Para las embarcaciones equipadas con listones, no es necesario retirarlos durante el plegado.
4. **Retire** los tapones de los desagües rápidos, y **vacíe** el agua que podría haber en la embarcación (en caso de almacenamiento prolongado, cerciőrese de que la embarcación esté bien seca antes de plegarla).
5. **Repliegue** los 2 costados del flotador hacia el interior de la embarcación (A), lleve los conos contra el tablero (B), y luego enrolle la embarcación sobre sí misma, alrededor del tablero (C). Repita la operación si observa que queda aire en los flotadores.

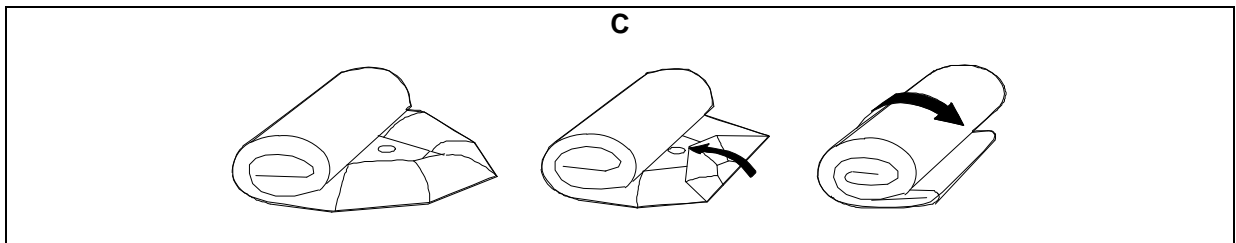
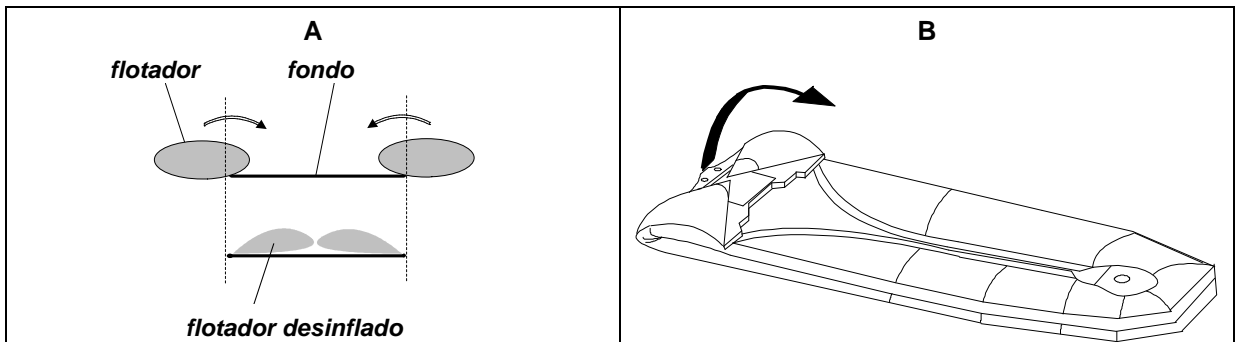

6. **Coloque** la embarcación plegada sobre su bolsa.



DESCRIPTION - DESCRIZIONE - BESCHREIBUNG - DESCRIPCIÓN

	200 Roll Up	200 Aero	230 Roll Up	230 Aero	270 Roll Up	270 Aero	270 Alu	310 Aero	310 Alu	350 Aero	350 Alu
---	--------------------------	--------------------	--------------------------	--------------------	--------------------------	--------------------	-------------------	--------------------	-------------------	--------------------	-------------------



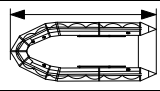
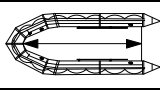
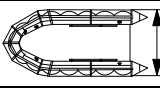
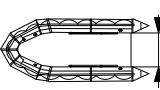
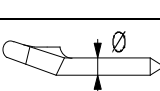

Dimensions – Dimensions – Dimensioni – Abmessungen – Dimenciones

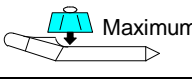
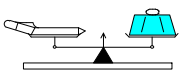
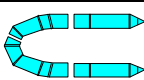
	(m)	2.00	2.00	2.30	2.30	2.70	2.70	2.70	3.10	3.10	3.50	3.50
	(ft)	6'7"	6'7"	7' 7"	7'7"	8'10"	8'10"	8'10"	10'2"	10'2"	11' 6"	11'6"
	(m)	1.26	1.26	1.44	1.44	1.75	1.75	1.75	2.20	2.20	2.58	2.58
	(ft)	4'2"	4'2"	4' 9"	4'9"	5'9"	5'9"	5'9"	7'3"	7'3"	8'6"	8'6"
	(m)	1.34	1.34	1.34	1.34	1.53	1.53	1.53	1.55	1.55	1.72	1.72
	(ft)	4'5"	4'5"	4' 5"	4'5"	5'	5'	5'	5'1"	5'1"	6' 4"	6' 4"
	(m)	0.62	0.62	0.62	0.62	0.68	0.68	0.68	0.68	0.68	0.83	0.83
	(ft)	2'0"	2'0"	2'0"	2'0"	2'3"	2'3"	2'3"	2'3"	2'3"	2'9"	2'9"
	(m)	0.36	0.36	0.36	0.36	0.43	0.43	0.43	0.44	0.44	0.45	0.45
	(ft)	1'2"	1'2"	1'2"	1'2"	1'5"	1'5"	1'5"	1'5"	1'5"	1'6"	1'6"

Capacité - Capacity - Capacità - Kapazität – Capacidad

 (ISO)		2	2	2+1	2+1	3+1	3+1	3+1	5	5	6	6
 Maximum	Kg*	180	230	270	350	370	480	450	650	600	700	650
	lb.*	396	507	595	772	816	1058	992	1433	1323	1543	1433
	Kg**	20	20	22	24	29	31	37	35	40	42	67
	lb.**	44	44	49	53	64	68	82	77	88	93	148
		2	2+1	2	2+1	3	3+1+1	3+1	3+1+1	3+1	3+1+1	3+1

Motorisation - Outboard data - Motorizzazione - Außenbordmotor – Motorización

		S	S	S	S	S	S	S	S	S	S	S
	Maximum CV***	3	3	4	4	4	6	8	10	15	15	20
	Maximum kW***	2.3	2.3	3	3	3	4.5	6	8	12	12	15
	Medium CV***	3	3	3	3	3	4	6	8	10	10	15
	Medium kW***	2.3	2.3	2.2	2.2	2.2	3	4.5	6	8	8	12
	kg	18	18	27	27	27	27	42	52	55	55	55
	Lbs.	40	40	60	60	60	60	93	115	121	121	121

Encombrement - Storage dimensions - Ingombro - Packmaße - Dimenciones

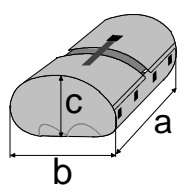
	a	0.98 3'3"	0.97 3'2"	0.98 3'3"	1.00 3'3"	1.10 3'7"	1.09 3'7"	1.3 4'3"	1.14 3' 9"	1.05 3'5"	1.2 3'11"	1.24 4'10"
	b	0.54 1'9"	0.42 1'5"	0.51 1'8"	0.57 1'10"	0.50 1'8"	0.52 1'8"	0.62 2'0"	0.59 2'2"	0.63 2'1"	0.64 2'1"	0.6 1'11"
	c	0.27 0'11"	0.28 0'11"	0.30 0'12"	0.29 0'11"	0.37 1'3"	0.32 1'1"	0.34 1'1"	0.32 1'1"	0.35 1'2"	0.32 1'1"	0.30 0'12"

	94/25/CE 03/44/CE	-	-	-	-	D	D	D	C	C	C	C
--	----------------------	---	---	---	---	---	---	---	---	---	---	---

<p>NOTE NOTICE : NOTA : HINWEIS :</p>	<p>Toutes les mesures indiquées sont susceptibles de varier de + ou - 3% All dimensions indicated have a tolerance of +/- 3% Tutte le dimensioni indicate hanno una tolleranza del +/- 3% Alle angegebenen Abmessungen haben eine Toleranz von +/- 3%. Todas las dimensiones tienen una tolerancia de +/- 3%</p> <p>Poids, weight, peso, Gewicht, peso : +/- 5%</p>
--	---

* The maximum payload has been calculated according to ISO standards. Operating at or near maximum payload is only advised in calm water and at reduced speeds.

** The weights indicated do not include any accessories

***The spread of engine sizes corresponds to the efficient use of the boat with an average load. The minimum power is exploitable in relaxed activities, such as fishing, while the maximum recommended power is destined for performance activities such as water-skiing.

Where the maximum power exceeds the recommended power it must be treated with extreme care.

* La charge maximale autorisée a été calculée selon la norme ISO. Il est recommandé de naviguer avec précaution lorsque le bateau est chargé au maximum.

** Poids indiqués hors accessoires

***Les puissances conseillées correspondent à une exploitation optimale des capacités du bateau pour une charge moyenne. Selon l'utilisation, vous choisirez la puissance maximale (ski nautique) ou minimale (pêche, promenade).

Utilisez la puissance maximale autorisée avec une extrême prudence (voir Tome 1 du manuel, chapitre "Conseils de navigation").

* La portata massima autorizzata è calcolata in conformità alla normativa ISO. In condizioni di massimo carico si raccomanda di navigare con particolare prudenza.

** Pesi s'intendono accessori esclusi

***Le potenze suggerite corrispondono ad uno sfruttamento ottimale delle capacità del battello, in condizioni medie di carico. In funzione del tipo di utilizzo prevalente, potrà essere preferita la motorizzazione massima (sci nautico) o minima (pesca, impiego familiare).

La potenza massima autorizzata deve essere sfruttata con prudenza.

* Die zulässige Nutzlast wurde gemäß ISO-Normen berechnet. Fahren mit oder nahe der zulässigen Nutzlast ist nur empfehlenswert in ruhigem Wasser und mit reduzierter Geschwindigkeit.

** Die Gewichtsangaben beinhalten kein Zubehör

***Die Bandbreite der Motorleistung entspricht einer optimalen Nutzung des Bootes bei durchschnittlicher Zuladung. Die minimale Motorleistung ist für entspannende Tätigkeiten wie Angeln, während die maximal empfohlene Motorleistung für hohe Fahrleistung wie Wasserski bestimmt ist.

Ist die zulässige Motorleistung größer als die empfohlene, muß mit äußerster Vorsicht gehandelt werden.

* La carga máxima autorizada se ha calculado según la norma ISO. Se recomienda navegar con precaución cuando la embarcación esté cargada al máximo.

** Pesi s'intendono accessori esclusi

***Las potencias aconsejadas corresponden a una explotación óptima de las capacidades de la embarcación para una carga media. Según la utilización, escogerá la potencia máxima (esquí náutico) ó mínima (pesca, paseo).

Utilice la potencia máxima autorizada con extrema prudencia.

DESCRIPTION - DESCRIPTION - BESCHREIBUNG - DESCRIZIONE - DESCRIPCIÓN

	Français	English	Italiano	Deutsch	Español
1	Valve de gonflement flotteur	Main buoyancy tube valve	Valvola di gonfiaggio tubolari	Ventile (Schauchkörper)	Válvula flotador principal
2	Valve de gonflement quille	Keel valve	Valvola di gonfiaggio chiglia	Ventile (Luftkeil)	Válvula de la quilla
3	Valve de gonflement plancher Aerotec	Aerotec air floor valve	Valvola di gonfiaggio Pagliolato Aerotec	Ventile Aerotec luftboden	Válvula suelo Aerotec
4	Plancher Aerotec	Aerotec air floor Aerotec air floor	Pagliolato Aerotec	Herausnehmbarer Aerotec luftboden	Suelo Aerotec
5	Lattes amovibles	Removable wooden slats	Pagliolato a listelli	Herausnehmbarer lattenboden	Tabillas extraíbles
6a					
6b	Plancher aluminium	Aluminium floor	Pagliato aluminium	Bodenelemente aus Aluminium	Enjaretado aluminium
7	Longerons	Stringers	Longheroni	Längsholme	Larguero
8	Quille gonflable	Inflatable keel	chiglia gonfiabile	Luftkeil	Quilla hinchable
9	Cône	Cone	Coni	Heckkonen	Cono
10	Extrémité de cône	Cone end	Coni (estremità)	Heckkonen (Ende)	Cono (extremidad)
11	Tableau arrière	Transom	Specchio di poppa	Heckspiegel	Tabla popa
12	Vide vite	Self bailer	Autovuotanti	Selbstlenzende Ventile	Desagües
13	Taquets tableau arrière	Retaining batten	tasselli	Beiden Niederhalter	Cuñas
14	Anneau de levage	Lifting rings	Anelli di sollevamento	Hebenringe	Anillos de levantamiento
15	Supports dames de nage	Rowlock blocks	Scalmi basculanti	Klappbare ruderdollen	Soportes chumaceras
16	Sangle réservoir	Fuel tank strap	Cinghie ferma serbatoio	Befestigungsgurt für Kraftstofftank	Sangla depósito
17	Poignée avant	Bow handle	Maniglia anteriore	Buggriff	Asa delantera
18	Poignée de portage	Carrying handle	Maniglie de trasporto	Tragegriffe	Asa de transporte
19	Anneau de remorquage	Towing ring	Anelli di rimorchio	Schleppringe	Anilla de arrastre
20	Bande antiragage périmétrique nervurée	Non-scuff rubbing strake	Bottaccio di protezione piatto perimetrale	Verstärkte Rundum-Scheuerleiste	Defensa periférica
21	Fixation sac avant (option)	Bow bag fixation (option)	Attacco borsa di prua	Befestigung (Bugstausack)	Fijación bolsa de proa (opcional)
22	Repose d'avirons	Oar rest	Sistemi di fissaggio dei remi	Ruderfixierungen	Sujeta remos
24	Banc & Support	Seat & support	Panchetta & Attacco	Sitzducht	Banqueta & Fijación
25	Patch poignées	Handles on patch	Maniglie / patch	Griffe / Patch	Asa / patch

CADET Roll Up

(lattes/slats/ latten/ tabillas/ Stecche)

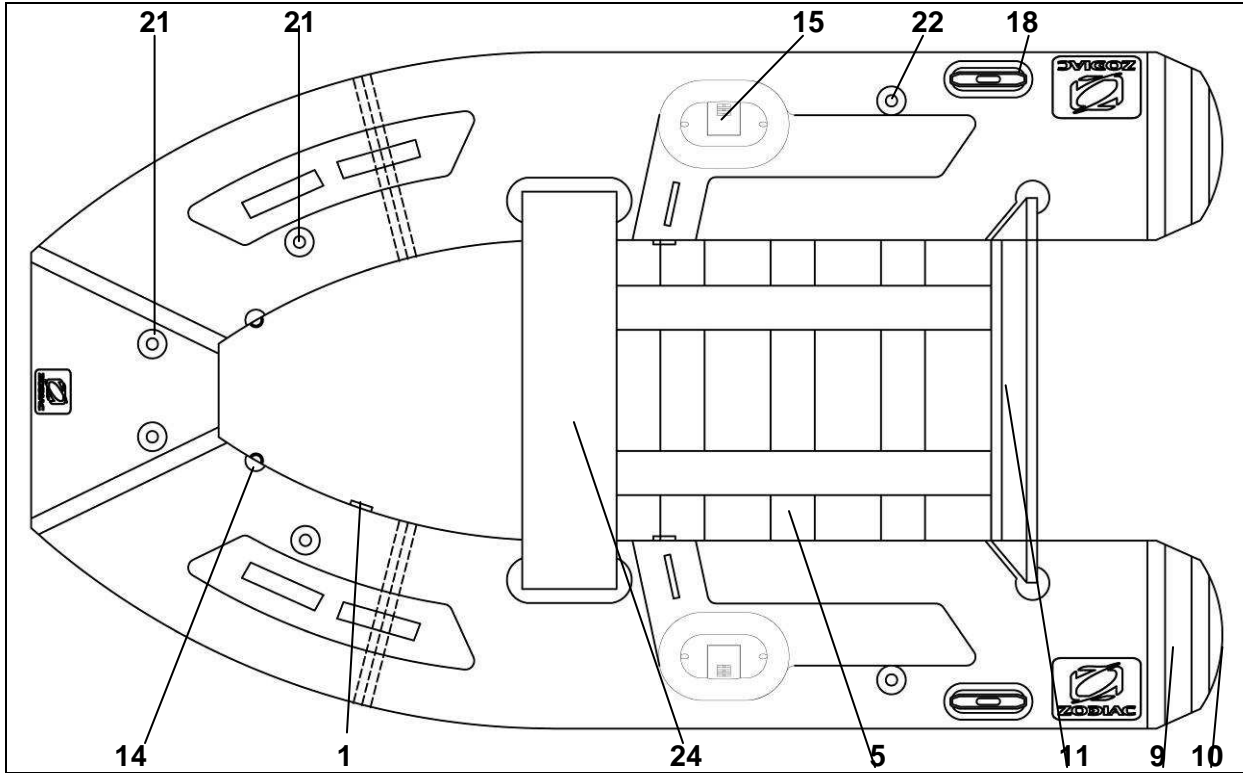

CADET Aero

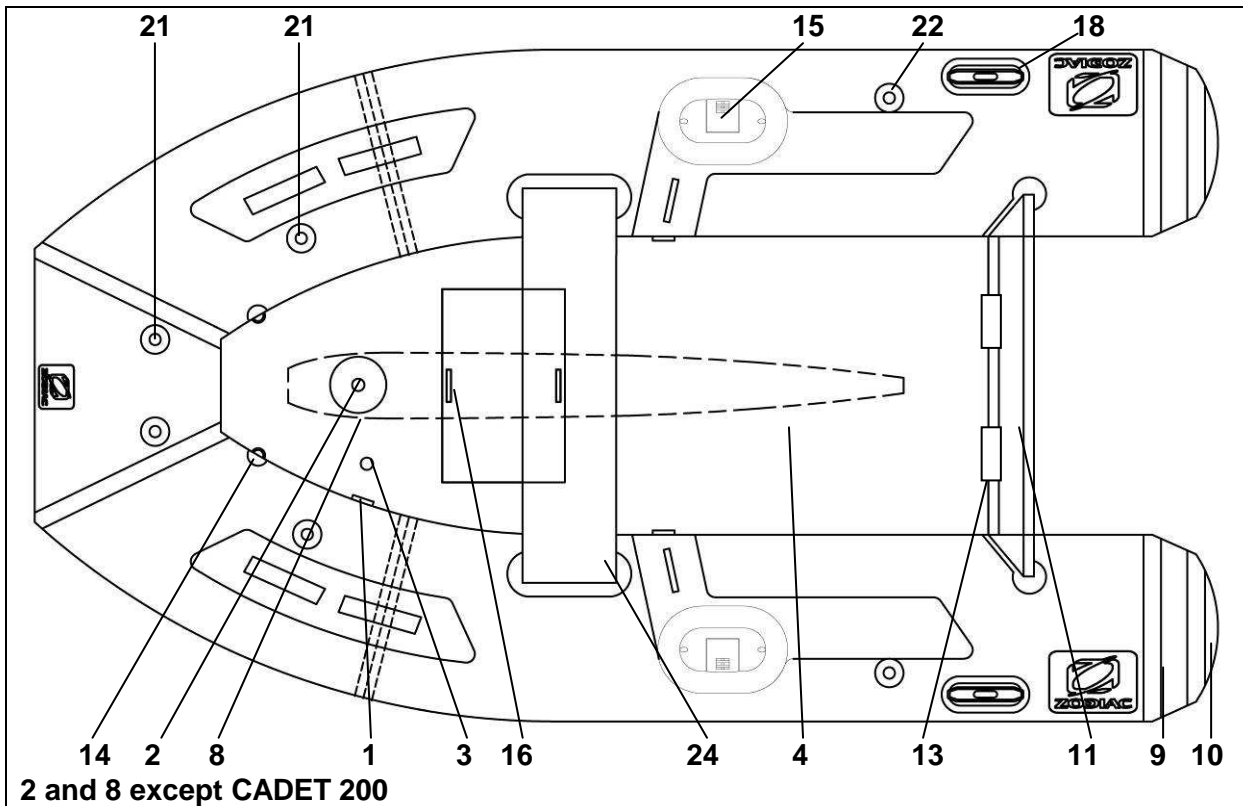

CADET Alu

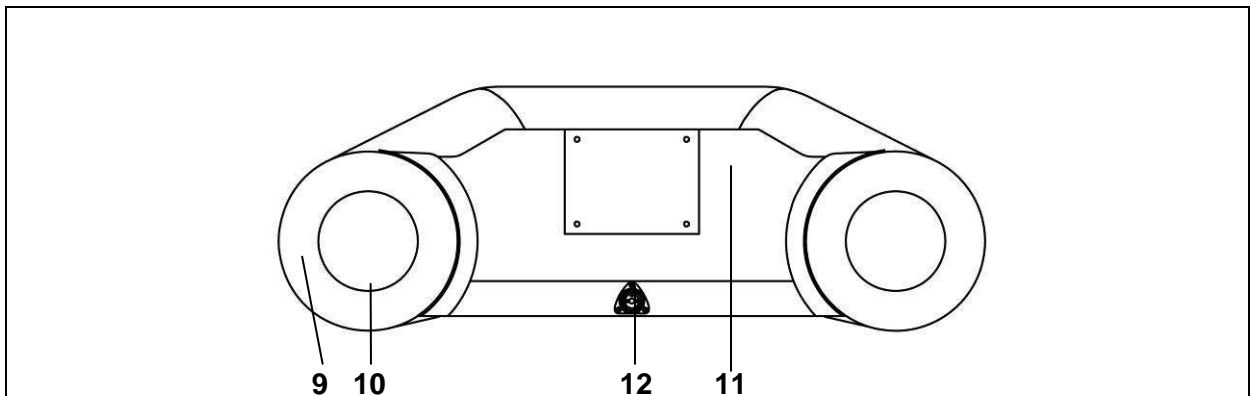
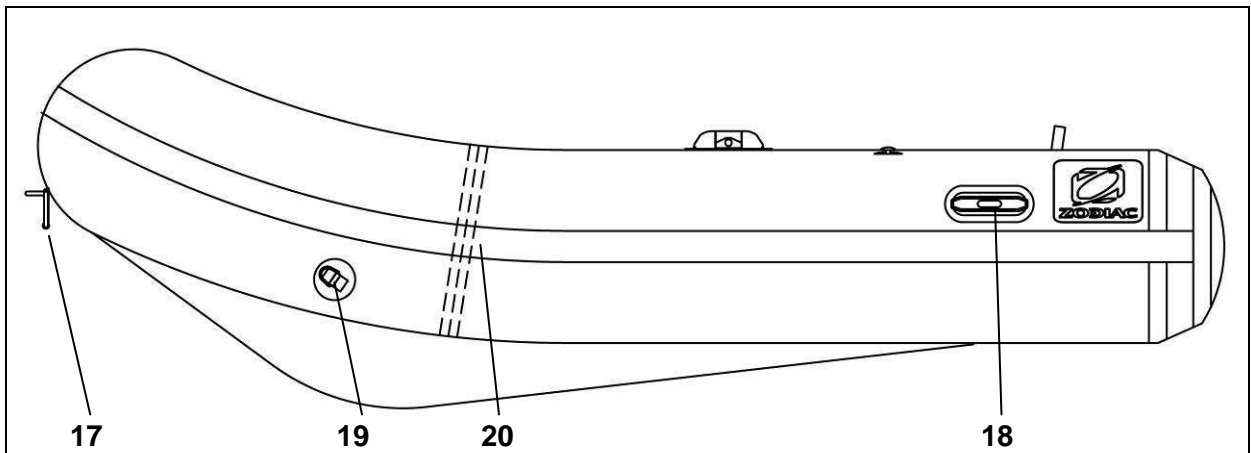
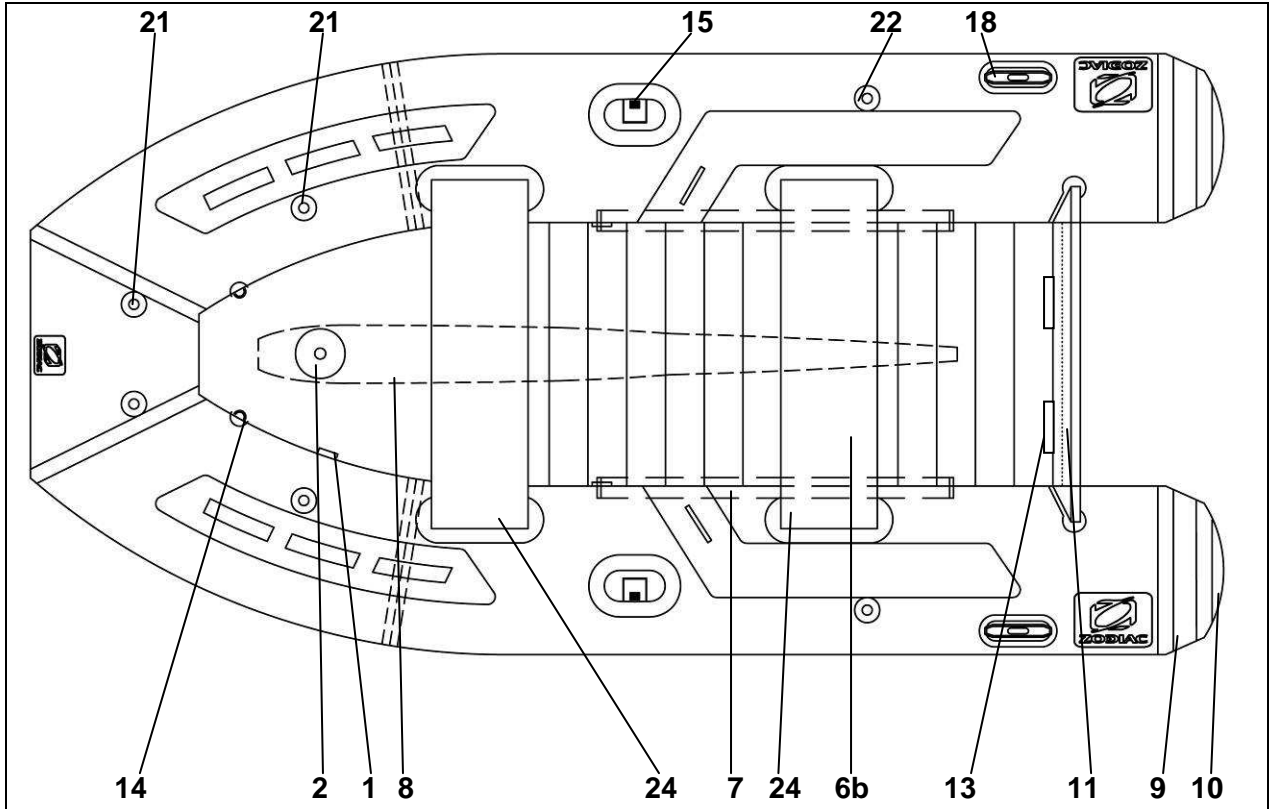



ZODIAC NAUTIC
20, rue Troyon
92316 SEVRES FRANCE

Edition 00



Zodiac NAUTIC
20, rue Troyon
92316 SEVRES FRANCE